

TECHNICAL INSTRUCTIONS

FOR

SPECIAL SERVICE CAMPAIGN 50J

**FRONT SUSPENSION LOWER BALL JOINT REPLACEMENT
FOR THE FOLLOWING VEHICLES**

**2001 THROUGH 2002 MODEL YEAR 4RUNNER
2001 THROUGH 2004 MODEL YEAR TACOMA 4WD & PRERUNNER
2002 THROUGH 2004 MODEL YEAR SEQUOIA & TUNDRA**

(Updated on July 27, 2005)

I. OPERATION FLOW CHART

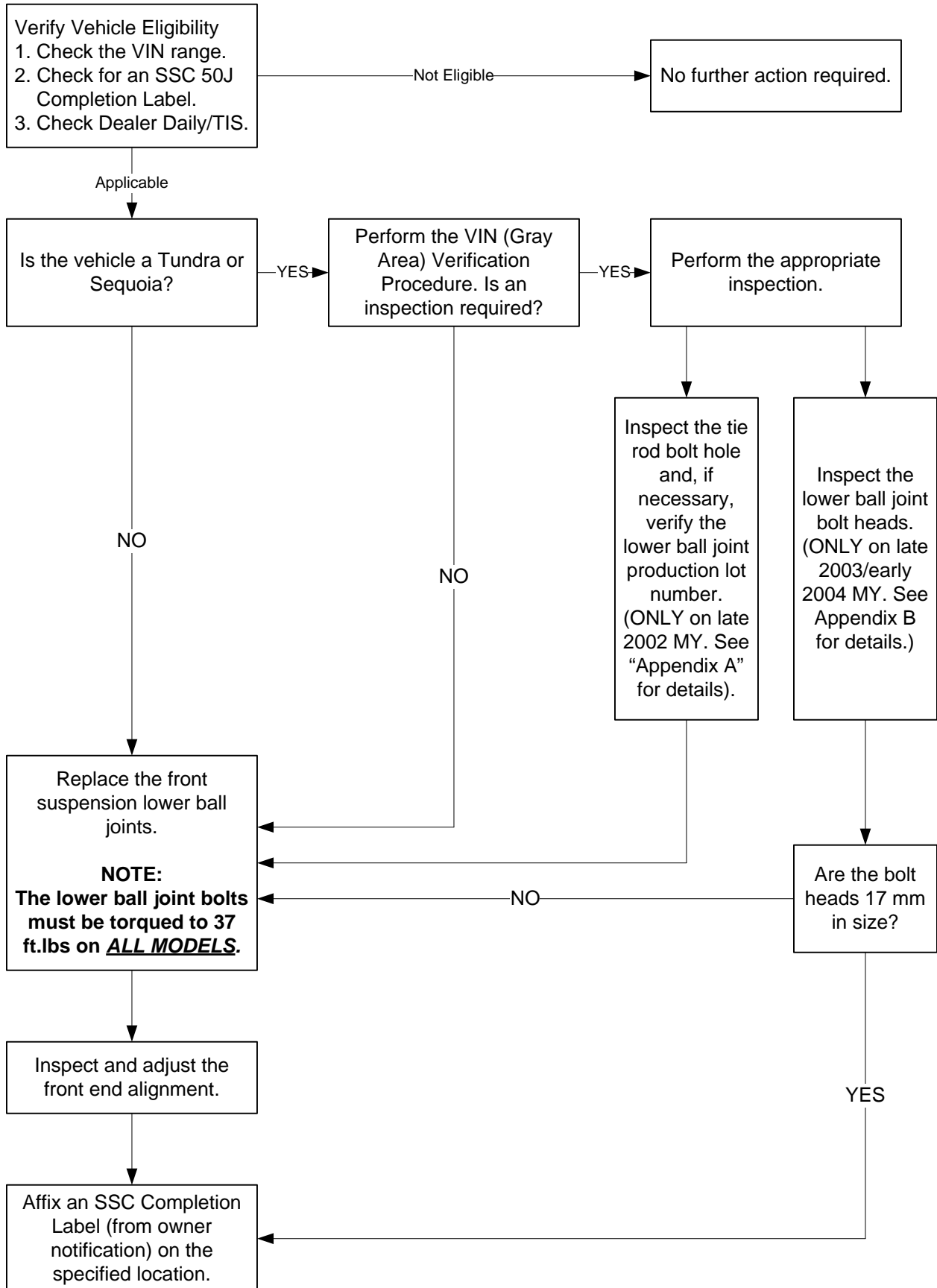

II. IDENTIFICATION OF AFFECTED VEHICLES

A. AFFECTED VIN RANGE

Model	Year	VIN Range	
		VDS	Range
4Runner	2001	GN86R	0213797 – 0219319
		GN87R	0213798 – 0219315
		HN86R	0356596 – 0360805
			9057980 – 9060573
	HN87R	0356571 – 0360794	
		9057954 – 9060571	
	2002	GN86R	0217600 – 0259664
		GN87R	0217601 – 0259661
			9000001 – 9001238
		HN84R	0359536 – 0392171
HN86R		0359537 – 0392220	
		9059911 – 9078746	
HN87R	0360807 – 0392182		
	9060576 – 9078745		

Model	Year	VIN Range	
		VDS	Range
Sequoia	2002	BT44A	S057702 – S137479
		BT48A	S057598 – S137474
		ZT34A	S057720 – S137484
		ZT38A	S057509 – S137473
	2003	BT44A	S101211 – S205101
		BT48A	S099426 – S205111
		ZT34A	S100033 – S205190
		ZT38A	S100343 – S205189
	2004	BT44A	S205112 – S209099
		BT48A	S205113 – S209101
		ZT34A	S205197 – S209916
		ZT38A	S205191 – S209912

[Identification of Affected Vehicles Continued...]

Model	Year	VIN Range	
		VDS	Range
Tacoma 4WD & PreRunner	2001	GM92N	Z864889 – Z880431
		GN92N	Z864569 – Z880433
		HN72N	Z864097 – Z880444
		NM92N	Z864158 – Z880427
		PM62N	Z864334 – Z880351
		SM92N	Z864823 – Z880439
		SN92N	Z864591 – Z880436
		WM72N	Z864356 – Z880443
		WN72N	Z864001 – Z880438
	2002	GM92N	Z000001 – Z899998
		GN92N	Z000190 – Z899894
		HN72N	Z000002 – Z899999
		NM92N	Z000233 – Z899936
		PM62N	Z000022 – Z899995
		SM92N	Z000245 – Z899972
		SN92N	Z000012 – Z899646
		WM72N	Z000058 – Z899904
		WN72N	Z000019 – Z899885
	2003	GM92N	Z145585 – Z305459
		GN92N	Z145318 – Z305507
		HN72N	Z145460 – Z305500
		NM92N	Z145535 – Z305379
		PM62N	Z145471 – Z305481
		SM92N	Z145555 – Z305506
		SN92N	Z145622 – Z305491
		WM72N	Z145487 – Z305493
		WN72N	Z145316 – Z305501
	2004	GM92N	Z305895 – Z357444
		GN92N	Z305509 – Z357433
		HN72N	Z305686 – Z357097
		NM92N	Z305853 – Z357252
		PM62N	Z305763 – Z357398
		SM92N	Z305863 – Z357356
		SN92N	Z305944 – Z357209
		WM72N	Z305789 – Z357348
		WN72N	Z305508 – Z357376

[Identification of Affected Vehicles Continued...]

Model	Year	VIN Range	
		VDS	Range
Tundra	2002	BN441	S221070 – S332707
		BT441	S220869 – S332720
		BT481	S220923 – S332685
		JN321	S220722 – S332714
		KT421	S221163 – S328382
		KT441	S221132 – S332706
		RN341	S220884 – S332719
		RT341	S220478 – S332721
		RT381	S220953 – S332666
	2003	BN441	S332744 – S434010
		BT441	S316368 – S439612
		BT481	S306031 – S439613
		JN321	S332745 – S436914
		KT421	S332818 – S414089
		KT441	S330788 – S439601
		RN341	S307943 – S436915
		RT341	S306032 – S439732
		RT381	S308386 – S439716
	2004	BN441	S434011 – S434105
		BT441	S439614 – S441496
		BT481	S439615 – S441489
		JN321	S436917 – S438452
		KT441	S439633 – S441402
		RN341	S436916 – S438449
RT341		S439161 – S441893	
RT381		S439739 – S441891	

NOTE:

Not all vehicles in the VIN range are affected. As always, consult Dealer Daily/TIS to confirm VIN eligibility and to assure the SSC is applicable. This will verify the vehicle is affected and has not already been completed prior to dealer shipment or by another dealer. TMS warranty will not reimburse dealers for repairs conducted on vehicles that are not affected or were completed by another dealer.

III. PREPARATION

A. PARTS

- 4Runner

Part Number	Part Description	Qty.
04005-02235	Lower Ball Joint Kit	1

- Tacoma 4WD & PreRunner

Part Number	Part Description	Qty.
04005-03235	Lower Ball Joint Kit	1

There are two different Lower Ball Joint Kit part numbers applicable to Sequoia and Tundra vehicles based upon model and production date. To assist dealers in determining the correct part number to order, a website has been set up to look up part numbers by VIN. Please go to <http://50jlookup.imagespm.info> (also linked through TIS), enter the VIN, and the correct part number to order will be displayed. ***The website is for part application reference only and will not order the part nor will it confirm campaign completion status.***

After checking the website and prior to ordering parts, a vehicle inspection will be required on late 2002 and late 2003/early 2004 Sequoia and Tundra vehicles.

On late 2002 MY vehicles, an inspection of the tie rod bolt hole and, if necessary, verification of the lower ball joint production lot number will determine the correct parts application (see "Appendix A" for details). On late 2003/early 2004 MY vehicles, an inspection of the lower ball joint bolt heads will determine if the vehicle is involved (see "Appendix B" for details).

- Sequoia and Tundra (Production Date: August, 2001 ~ July/August, 2002)

Part Number	Part Description	Model	Qty.
04005-04134	Lower Ball Joint Kit	Sequoia	1
		Tundra	

- Sequoia and Tundra (Production Date: July/August, 2002 ~ September, 2003)

Part Number	Part Description	Model	Qty.
04005-21134	Lower Ball Joint Kit	Sequoia	1
		Tundra	

B. TOOLS

- Standard hand tools
- Special Service Tools
 - (a) Pitman Arm Puller: 09610-20012 or equivalent
 - (b) Ball Joint Puller: 09628-62011 or 00002-07311 or equivalent
- Torque wrench

IV. COMPONENTS

A. 4Runner

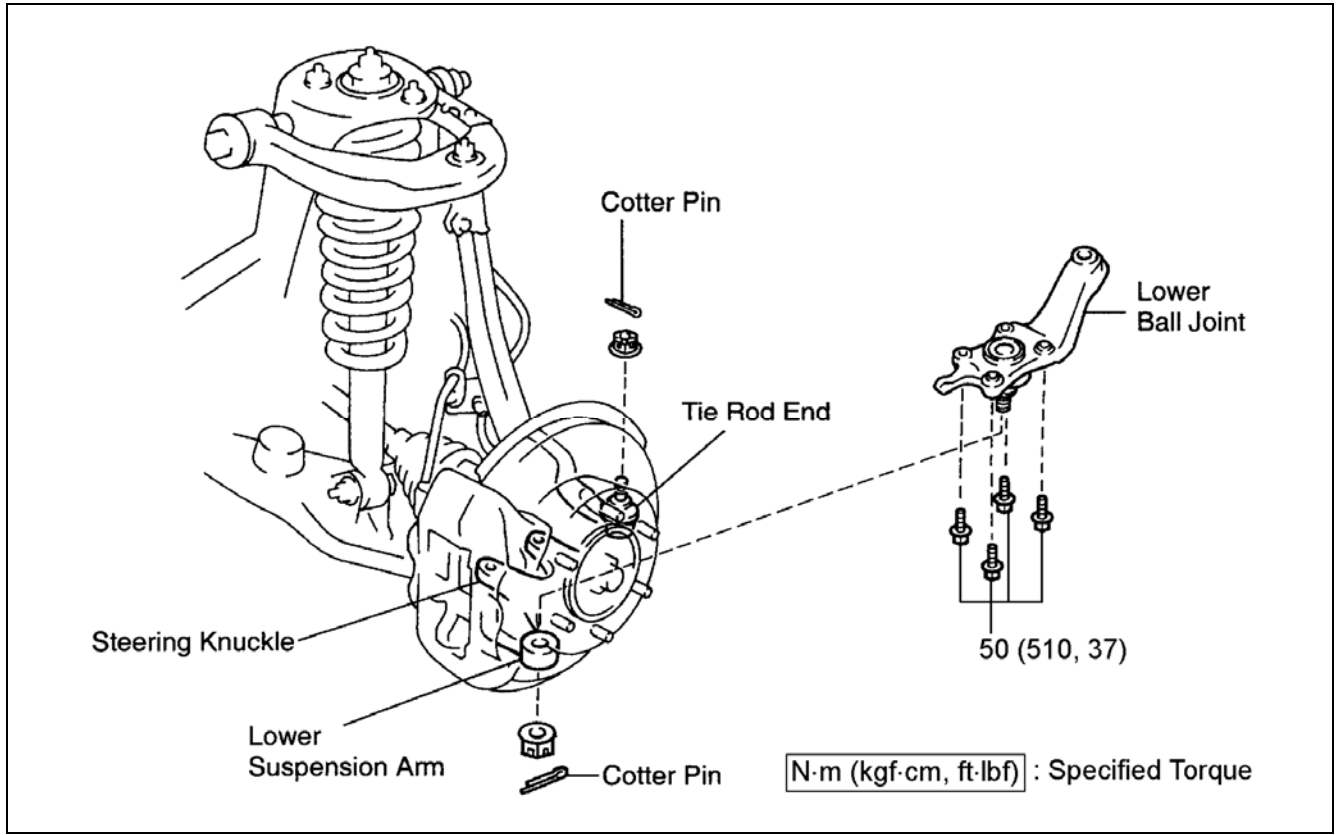

B. Tacoma 4WD & PreRunner

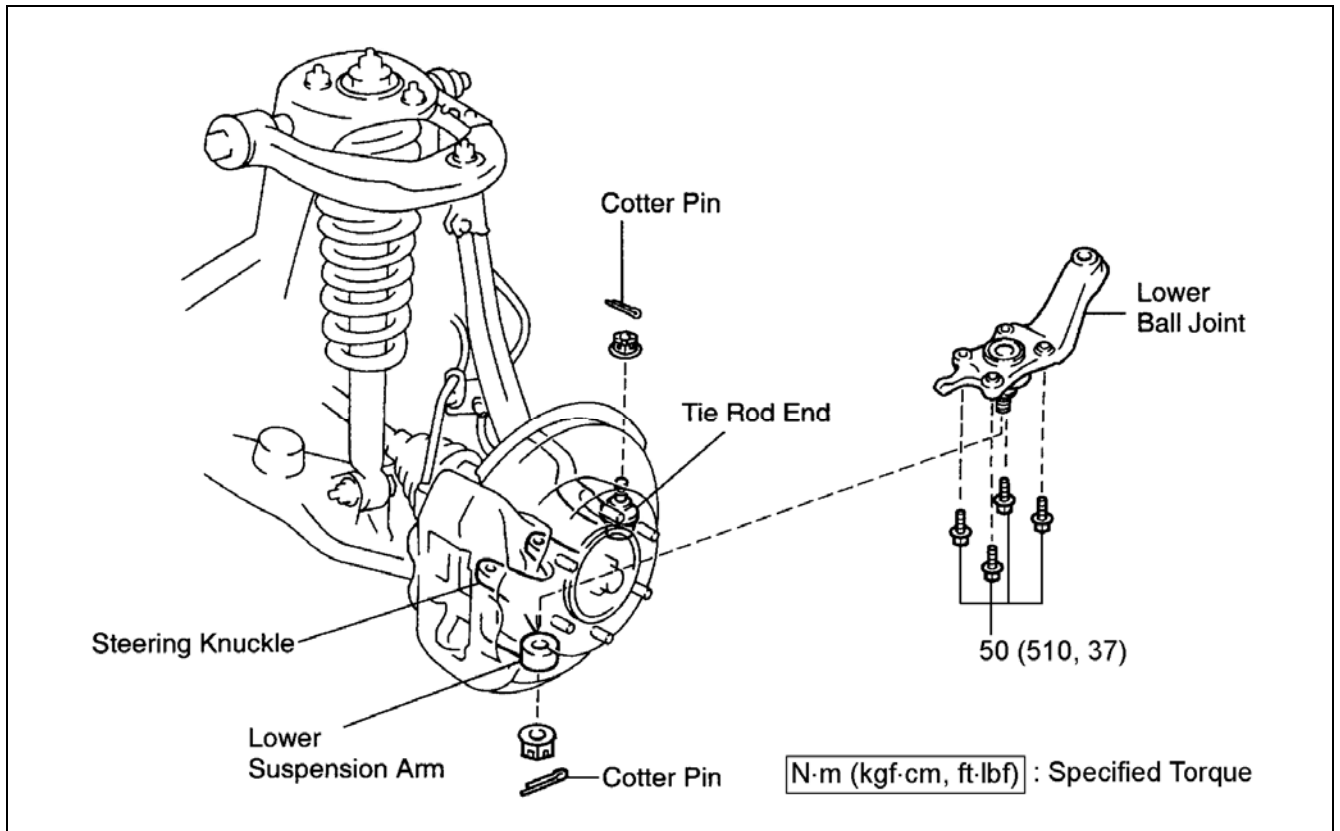

C. Sequoia & Tundra

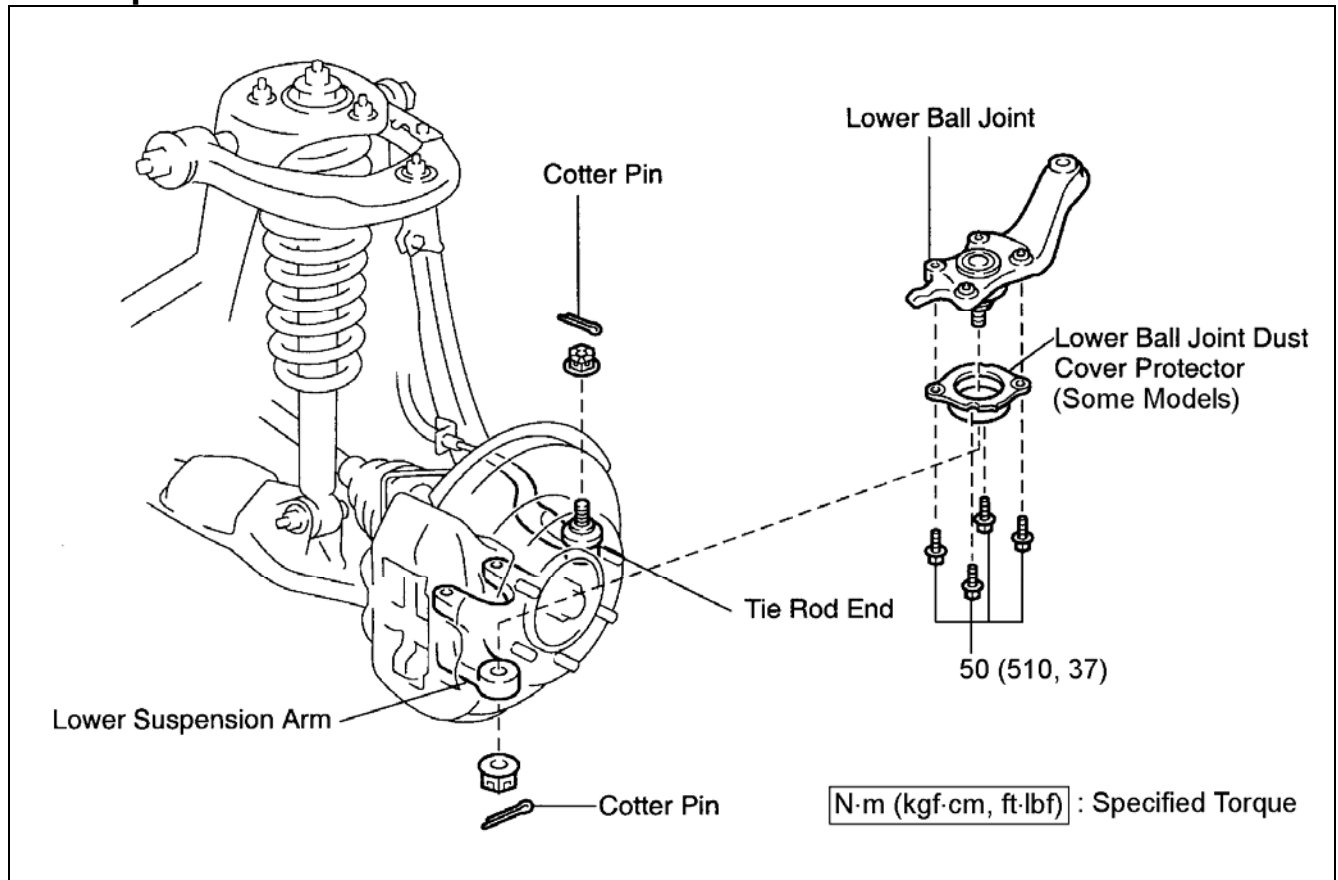

V. BACKGROUND

On certain 2001 – 2002 Model Year 4Runner, 2001 – mid-2004 Model Year Tacoma 4WD and PreRunner, and 2002 – early 2004 Model Year Sequoia and Tundra vehicles, there is a possibility that the Front Suspension Lower Ball Joint may experience excessive wear and looseness causing increased steering effort, reduced vehicle self-centering, and noise in the front suspension.

VI. VIN (GRAY AREA) VERIFICATION PROCEDURE (ONLY FOR SEQUOIA AND TUNDRA VEHICLES)

1. The Sequoia and Tundra vehicles in the VIN ranges below will require the inspection outlined in “**APPENDIX A. INSPECT THE SIZE OF THE TIE ROD BOLT HOLE ON THE LOWER BALL JOINT**”.

MODEL	YEAR	VDS	START	END
Sequoia	2002	BT44A	S136362	S137479
		BT48A	S136360	S137474
		ZT34A	S136356	S137484
		ZT38A	S136364	S137473

MODEL	YEAR	VDS	START	END
Tundra	2002	BN441	S332613	S332707
		BT441	S330331	S332720
		BT481	S330344	S332685
		JN321	S330791	S332714
		KT441	S330407	S332706
		RN341	S330794	S332719
		RT341	S330792	S332721
		RT381	S330795	S332666

2. The Sequoia and Tundra vehicles in the VIN ranges below will require the inspection outlined in “**APPENDIX B. INSPECT THE SIZE OF THE LOWER BALL JOINT BOLT HEADS**”.

MODEL	YEAR	VDS	START	END
Sequoia	2004	BT44A	S206013	S209099
		BT48A	S205495	S209101
		ZT34A	S206169	S209916
		ZT38A	S206167	S209912

MODEL	YEAR	VDS	START	END
Tundra	2003	BN441	S433917	S434010
		BT441	S437555	S439612
		BT481	S437842	S439613
		JN321	S435972	S436914
		KT441	S438306	S439601
		RN341	S435838	S436915
		RT341	S437758	S439732
		RT381	S438287	S439716
	2004	BN441	S434011	S434105
		BT441	S439614	S441496
		BT481	S439615	S441489
		JN321	S436917	S438452
		KT441	S439633	S441402
		RN341	S436916	S438449
		RT341	S439161	S441893
RT381	S439739	S441891		

VII. WORK PROCEDURE

A. FRONT SUSPENSION LOWER BALL JOINT REPLACEMENT

1. Replace the front suspension lower ball joints following the procedures outlined in the **Suspension And Axle: Front Lower Ball Joint** section of the appropriate vehicle Repair Manual.

Please refer to the torque specifications on page 7 and 8 of this document for the 4 bolts that attach the ball joint to the steering knuckle.

B. INSPECT AND ADJUST THE FRONT END ALIGNMENT

1. Inspect and adjust the front End alignment following the procedures outlined in the **Suspension And Axle: Front Wheel Alignment** section of the appropriate vehicle Repair Manual.

VIII. SSC COMPLETION LABEL INSTALLATION

After completing the repair and before returning the vehicle to the owner, an SSC completion label, which is enclosed in the owner's notification letter, must be affixed to the left front door hinge post, near the check strap.

(a) The label is to be filled out as follows:

- Write in SSC 50J.
- Write in date of repair.
- Write in your dealer code.

SSC	Date
DEALER CODE NO.	
00410-01917	

- (b) Additional SSC completion labels, in sheets of 50 (P/N 00410-01917), may be ordered through the non-parts system on a 1450 order form or through the TDN system.

APPENDIX A: INSPECT THE SIZE OF TIE ROD BOLT HOLE ON THE LOWER BALL JOINT

NOTE:
THIS INSPECTION APPLIES ONLY TO THE SEQUOIA AND TUNDRA VEHICLES LISTED IN THE VIN RANGES BELOW.

MODEL	YEAR	VDS	START	END
Sequoia	2002	BT44A	S136362	S137479
		BT48A	S136360	S137474
		ZT34A	S136356	S137484
		ZT38A	S136364	S137473

MODEL	YEAR	VDS	START	END
Tundra	2002	BN441	S332613	S332707
		BT441	S330331	S332720
		BT481	S330344	S332685
		JN321	S330791	S332714
		KT441	S330407	S332706
		RN341	S330794	S332719
		RT341	S330792	S332721
		RT381	S330795	S332666

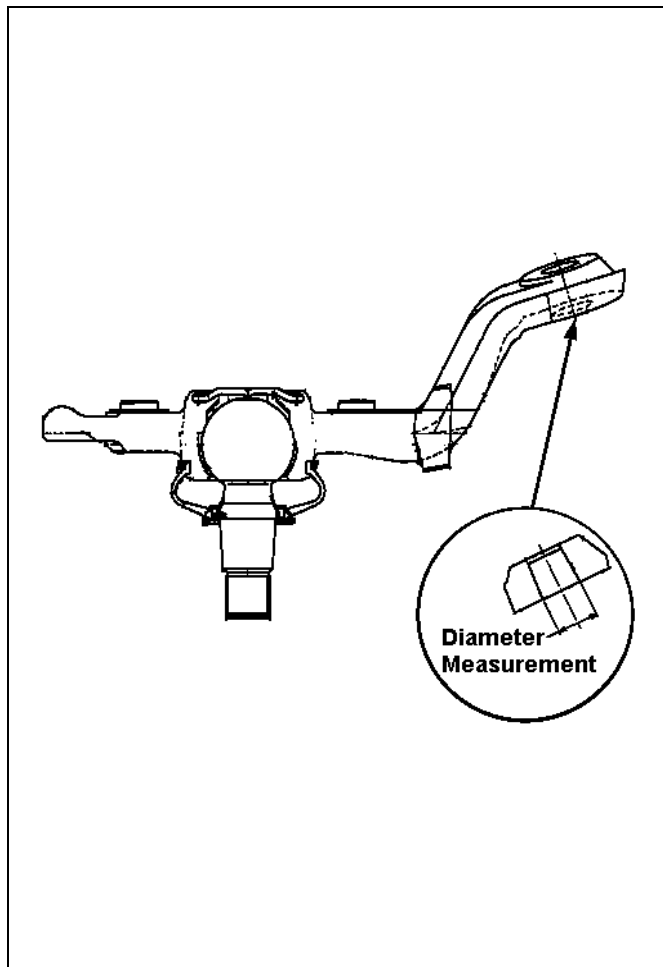

1. INSPECT THE DIAMETER OF THE TIE ROD BOLT HOLE

- (a) Disconnect the tie rod from the lower ball joint following the procedures outlined in the **Suspension And Axle: Front Lower Ball Joint** section of the appropriate vehicle Repair Manual.
- (b) Measure the diameter of the tie rod bolt hole, as shown in the illustration.
 - If the diameter is 16 mm, replace the lower ball joint using part **04005-04134**. Proceed to section **“VII. WORK PROCEDURE”**.
 - If the diameter is 17 mm, replace the lower ball joint using part **04005-21134**. Proceed to section **“VII. WORK PROCEDURE”**.
 - If the diameter of the tie rod bolt hole cannot be determined, the production lot number on the lower ball joint must be verified. Proceed to step **“2. LOCATE THE PRODUCTION LOT NUMBER”**.

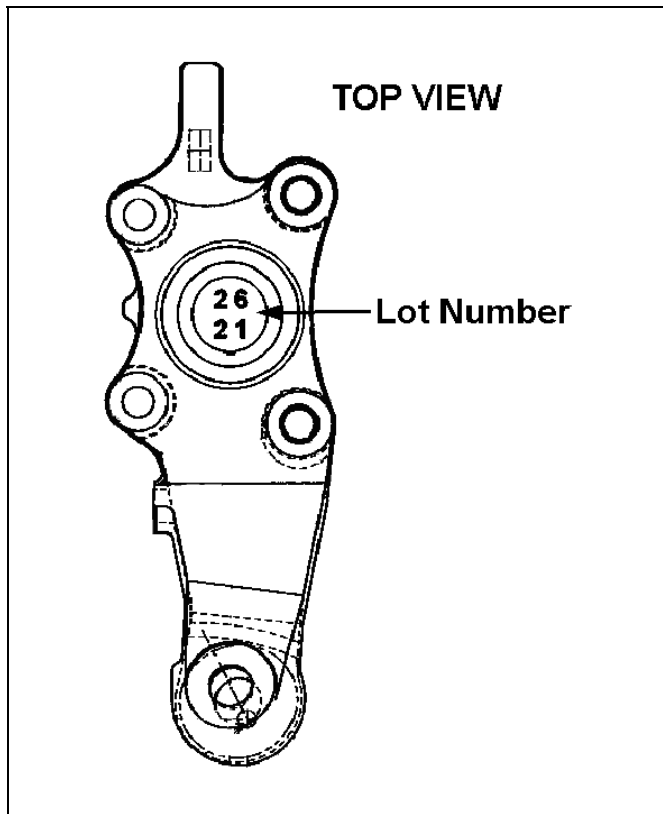

2. LOCATE THE PRODUCTION LOT NUMBER

- (a) Remove the lower ball joint following the procedures outlined in the **Suspension And Axle: Front Lower Ball Joint** section of the appropriate vehicle Repair Manual.
- (b) Locate the production lot number as shown in the illustration.

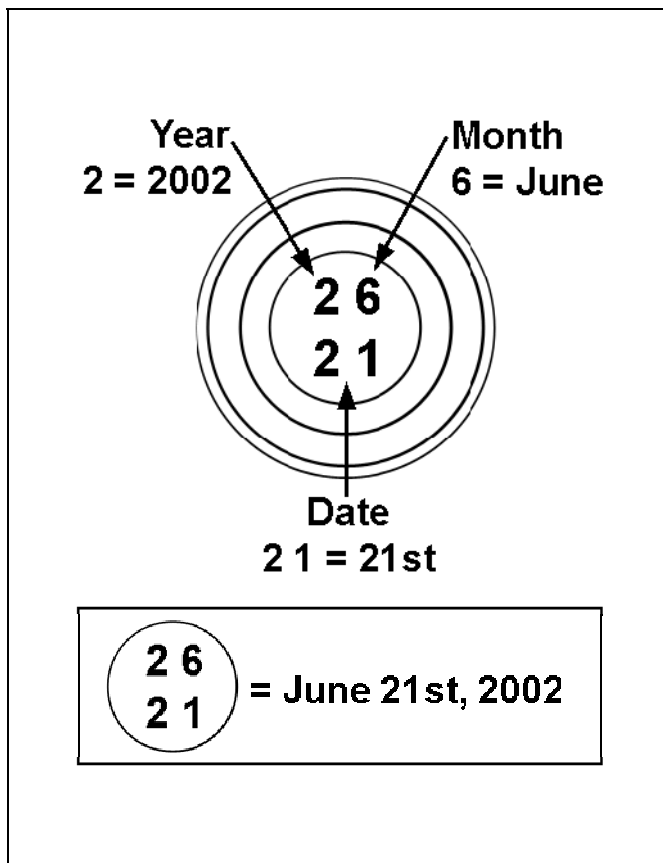

3. READING AND VERIFYING THE PRODUCTION LOT NUMBER

- (a) How to read the production lot number.
 - Upper Left Number: Year
 - Upper Right Number: Month
 - Bottom Numbers: Date
- (b) If the production lot number is...
 - **2620 (June 20th, 2002) or earlier**, replace the lower ball joint using part **04005-04134**. Proceed to section **“VII. WORK PROCEDURE”**.
 - **2622 (June 22nd, 2002) or later**, replace the lower ball joint using part **04005-21134**. Proceed to section **“VII. WORK PROCEDURE”**.

APPENDIX B: INSPECT THE SIZE OF THE LOWER BALL JOINT BOLT HEADS

NOTE:
THIS INSPECTION APPLIES ONLY TO THE SEQUOIA AND TUNDRA VEHICLES LISTED IN THE VIN RANGES BELOW.

MODEL	YEAR	VDS	START	END
Sequoia	2004	BT44A	S206013	S209099
		BT48A	S205495	S209101
		ZT34A	S206169	S209916
		ZT38A	S206167	S209912

MODEL	YEAR	VDS	START	END
Tundra	2003	BN441	S433917	S434010
		BT441	S437555	S439612
		BT481	S437842	S439613
		JN321	S435972	S436914
		KT441	S438306	S439601
		RN341	S435838	S436915
		RT341	S437758	S439732
		RT381	S438287	S439716
	2004	BN441	S434011	S434105
		BT441	S439614	S441496
		BT481	S439615	S441489
		JN321	S436917	S438452
		KT441	S439633	S441402
		RN341	S436916	S438449
		RT341	S439161	S441893
		RT381	S439739	S441891

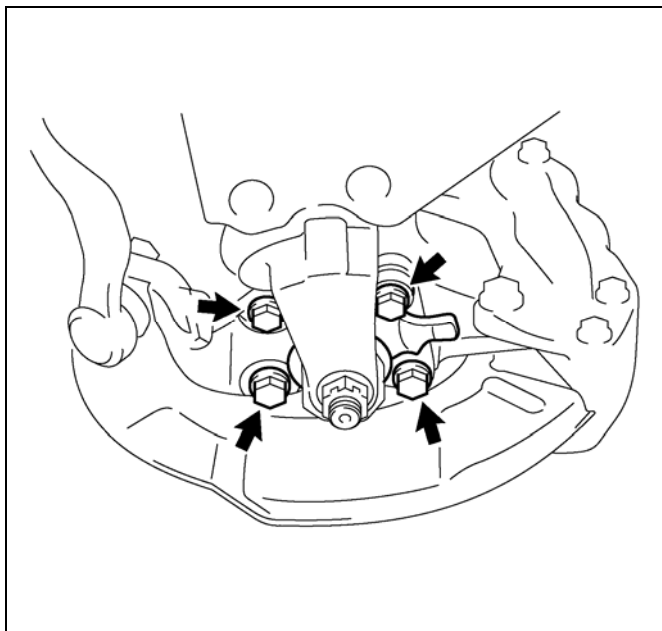

1. INSPECT THE SIZE OF THE BOLT HEADS FOR THE LOWER BALL JOINTS

- (a) Measure the lower ball joint bolt heads.
 - If the sizes of the bolt heads are 17 mm, lower ball joint replacement is **NOT NECESSARY**. Proceed to section “**VIII. SSC COMPLETION LABEL INSTALLATION**”.
 - If the sizes of the bolt heads are 14 mm, replace the lower ball joints using part **04005-21134**. Proceed to section “**VII. WORK PROCEDURE**”.