

To: All Toyota Dealer Principals, Service Managers, Parts Managers

Subject: ***Special Service Campaign – A7E Phase 1 (1998 – 2006 model year)***
Certain 1998 through 2010 Toyota Sienna 2WD Vehicles Equipped with a Spare Tire
Severe Corrosion of Spare Tire Carrier Cable

Earlier this year Toyota announced that a separate Special Service Campaign (SSC) will be launched for the 1998 - 2010 model year Sienna vehicles that are **NOT** currently registered in or originally sold-in the Severe Cold Climate States where road salts are frequently used. Although continued prolonged exposure to high concentrations of road salts and other cold climate environmental factors contribute to this condition, customers outside of the Severe Cold Climate States will be able to obtain the inspection and repair at **no charge** if they so desire.

Background

- This condition may occur if the subject vehicle is operated in cold climate regions of the United States where road salts are frequently used. Water can splash backwards with high concentrations of road salt, reach the spare tire carrier and corrode the spare tire carrier assembly cable.
- The SSC offers to apply* a Corrosion Resistant Compound (CRC) to the end of the spare tire carrier cable on certain 1998 – 2010 model year Sienna 2WD vehicles (equipped with a spare tire carrier) if the owner believes his/her vehicle will be operated in areas where a high concentration of road salt is frequently used. *Based upon inspection, if additional repairs are necessary, refer to the technical instructions for further details.
- Vehicles originally sold-in and currently registered in the following states and American Samoa, Guam, Puerto Rico and Saipan will receive this offer:

AK, AL, AR, AZ, CA, CO, FL, GA, HI, IA, ID, KS, LA, MO, MS, MT, NC, ND, NE, NM, NV, OK, OR, SC, SD, TN, TX, UT, WA, or WY

- This SSC will be launched in phases consistent with the age of the vehicle. Phase 1 will cover 1998 – 2006 model year Sienna vehicles. Subsequent phases will include the remaining Sienna vehicles covered by this SSC (2007 – 2010 model year):

Phase 1: Certain 1998 through 2006 Model Year Sienna 2WD vehicles

Phase 2: Certain 2007 through 2009 Model Year Sienna 2WD vehicles

Phase 3: Certain 2010 Model Year Sienna 2WD vehicles

Customers that receive the SSC notice may contact your dealership. If a customer requests that this SSC be performed, please be sure to assist them. If the customer opts not to conduct the SSC at this time, please leave the SSC open in the event the customer would like it performed in the future.

NOTE: Dealers located in the states covered by this SSC should not solicit opportunities to perform this campaign. Any abuse or misuse of this SSC will result in the dealer being debited.

The following vital information is provided to inform you and your staff of the owner notification phase of this campaign and your degree of involvement.

1. Owner Notification Mailing Date

The owner notification (Phase 1) will commence in mid-November 2010 approximately one week after the dealer notification. A separate dealer notification and activation of VINs in TIS will precede each subsequent phase of owner notification.

Please note that only owners of vehicles covered by the specific phase will be notified. If a dealership is contacted by an owner who has not yet received the notification, please **verify vehicle and phase coverage by confirming through Dealer Daily/TIS.**

Subsequent phases will be launched consistent with parts and repair capacity.

2. Dealer/Owner Lists

Phase 1 Summary Reports, containing the **number** of covered vehicles in your dealership’s primary marketing area, will be enclosed in the dealer package. **(Please verify vehicle and phase coverage by confirming through Dealer Daily or TIS prior to performing repairs.)**

3. Number and Identification of Covered Vehicles

Phase 1 will include certain 1998 through 2006 model year Sienna vehicles. The number of Sienna vehicles covered by Phase 1 is approximately 564,000.

| MODEL | WMI | MY | VDS | START - FINISH | PHASE |
|--------|-----|------|-------|-------------------|---------|
| Sienna | 4T3 | 1998 | GF13C | U000021 - U089580 | Phase 1 |
| | | | GF19C | U000018 - U089688 | |
| | | | MF19C | U000055 - U070516 | |
| | | | ZF13C | U000019 - U089730 | |
| | | | ZF19C | U000024 - U000080 | |
| | | 1999 | GF13C | U053491 - U068145 | |
| | | | GF19C | U068550 - U170823 | |
| | | | ZF13C | U051335 - U170866 | |
| | | | ZF19C | U052090 - U170766 | |
| | | 2000 | GF13C | U125596 - U125596 | |
| | | | GF19C | U126004 - U313293 | |
| | | | ZF13C | U124826 - U319642 | |
| | | | ZF19C | U127616 - U319641 | |
| | | 2001 | ZF13C | U250332 - U413538 | |
| | | | ZF19C | U253475 - U413527 | |
| | | 2002 | ZF13C | U382040 - U508298 | |
| | | | ZF19C | U411144 - U508296 | |
| | | 2003 | ZF13C | U476697 - U556504 | |
| | | | ZF19C | U476695 - U556507 | |

| MODEL | WMI | MY | VDS | START - FINISH | PHASE | |
|--------|-----|------|-------|-------------------|---------|---------|
| Sienna | 5TD | 2004 | ZA22C | S000027 - S221159 | Phase 1 | |
| | | | ZA23C | S000038 - S221166 | | |
| | | 2005 | ZA22C | S153073 - S387502 | | |
| | | | ZA23C | S152435 - S387528 | | |
| | | 2006 | ZA22C | S382736 - S587355 | | |
| | | | ZA23C | S381759 - S587357 | | |
| | | 2007 | ZK22C | S000015 - S099335 | | Phase 2 |
| | | | ZK23C | S000019 - S099342 | | |
| | | 2008 | ZK22C | S099346 - S225325 | | |
| | | | ZK23C | S099343 - S225607 | | |
| | | 2009 | ZK22C | S225335 - S289073 | | |
| | | | ZK23C | S222346 - S289074 | | |
| | | 2010 | KK4CC | S289076 - S343710 | | Phase 3 |
| | | | YK4CC | S289078 - S343708 | | |

(Number and Identification of Covered Vehicles Continued . . .)

Please note that only owners of the covered vehicles will be notified. If you are contacted by an owner who has not yet received the notification, please **verify vehicle and phase coverage by confirming through Dealer Daily or TIS prior to performing repairs**. Dealers should perform the procedure as outlined in the Technical Instructions located on TIS.

A UIO matrix by state is provided to inform your dealership of the number of affected vehicles in your state.

Sienna Vehicles 1998 – 2003 Model Year (Phase 1)

| State | UIO | State | UIO | State | UIO | State | UIO | State | UIO |
|-------|---------|-------|--------|-------|--------|-------|-------|-------|--------|
| AK | 377 | FL | 24,250 | LA | 3,461 | NE | 1,391 | SD | 374 |
| AL | 4,818 | GA | 14,054 | MO | 5,324 | NM | 1,765 | TN | 6,111 |
| AR | 1,795 | HI | 4,706 | MS | 1,475 | NV | 2,819 | TX | 27,580 |
| AZ | 6,285 | IA | 2,040 | MT | 630 | OK | 2,758 | UT | 3,302 |
| CA | 101,496 | ID | 1,299 | NC | 12,424 | OR | 6,222 | WA | 9,525 |
| CO | 7,218 | KS | 2,934 | ND | 223 | SC | 4,323 | WY | 331 |

Sienna Vehicles 2004 – 2006 Model Year (Phase 1)

| State | UIO | State | UIO | State | UIO | State | UIO | State | UIO |
|-------|--------|-------|--------|-------|--------|-------|-------|-------|--------|
| AK | 304 | FL | 32,632 | LA | 5,066 | NE | 1,636 | SD | 714 |
| AL | 5,153 | GA | 14,968 | MO | 6,091 | NM | 1,833 | TN | 6,433 |
| AR | 2,568 | HI | 4,574 | MS | 1,776 | NV | 3,628 | TX | 29,388 |
| AZ | 8,977 | IA | 3,614 | MT | 679 | OK | 2,872 | UT | 4,349 |
| CA | 99,947 | ID | 1,619 | NC | 14,640 | OR | 5,420 | WA | 10,110 |
| CO | 5,351 | KS | 4,035 | ND | 469 | SC | 5,819 | WY | 399 |

Note: To avoid confusion, the UIO provided above does not reflect the number of vehicles originally sold in these states which now reside in other states. Dealerships are requested to review their UIO report for SSC A7E in these cases.

4. Remedy Procedures

For additional information on inspection, repair, and CRC application please refer to TIS.

Review all applicable, open Safety Recall and Service Campaigns on the vehicle during the time of appointment. Follow the instructions for each as applicable.

5. Corrosion Resistant Compound (CRC)

As continued prolonged exposure to high concentrations of road salts and other cold climate environmental factors contribute to this condition, the majority of vehicles in your area will only require inspection and application of the CRC. Noxudol 300 has been selected as the CRC for this SSC. Follow the instructions below to order Noxudol 300 from Noxudol U.S.A.

The Noxudol 300 (corrosion resistant compound – CRC) for application to the spare tire carrier cable can be ordered directly through Noxudol at the following contacts:

- Product:** Noxudol 300
- Internet:** <http://www.noxudolusa.com/noxudolstore/ccp0-prodshow/N300D.html> (Aerosol Can)
<http://www.noxudolusa.com/noxudolstore/ccp0-prodshow/N300C.html> (1 Liter Bottle)
- Telephone:** 818-308-8430 (please use the website if the phone is busy)
- Application:** *1 aerosol can or 1 liter bottle can coat approximately 50 – 75 spare tire carrier cables.*
- Maximum Order Quantity:** A maximum order quantity of one aerosol can **or** one 1-liter bottle per week for each dealer has been placed on the Noxudol 300.

6. Special Circumstances (Special Service Tools and Parts)

In the unlikely event a spare tire carrier cable requires further repair, the following equipment and parts will be required:

Special Service Tool

In mid-October 2010 your dealership was sent an SSC A7E tool kit. This shipment included the required Crimp Die that will be used to attach a new ferrule to a repaired spare tire carrier cable. The kit also included a check gauge needed to ensure the ferrule was properly crimped on the cable (refer to the TI located on TIS for proper use of this tool kit).

When received, the SSC tool kit package had a fluorescent (green, orange, yellow or pink) label like the sample seen below for easy identification.

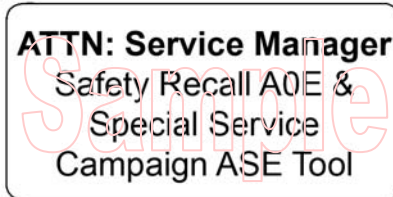

The additional required tools and equipment are listed in the technical instructions found on TIS.

Parts

Spare Tire Carrier Cable repair parts can be ordered through your dealership's facing PDC. Parts have been placed on Manual Allocation and a maximum order quantity of 20 pieces can be ordered daily up to the dealer total allocation quantity. Total allocation quantity is based on dealer repair order percentage x PDC affected UIO. Dealers that exceed their total allocation quantity must contact their facing PDC Customer Service Leader and request they submit a Special Request Form with quantity needed to the Special Activity Team.

| Part Number | Facing PDC | | Daily Maximum Order Quantity |
|-------------|------------|----|--------------------------------|
| 04000-40108 | 11 | | Released on case by case basis |
| 04000-40208 | 12 | | |
| 04000-41145 | 13 | | |
| 04000-40108 | 16 | 21 | 20 pieces per day |
| 04000-40208 | 17 | 22 | |
| 04000-41145 | 18 | 23 | |

Please refer to the following table and the Technical Instructions (located on TIS) for part number information.

1998 – 2003 Sienna Vehicles

| Part Number | Part Description | Quantity |
|-------------|---------------------------------|-----------------|
| 04000-40108 | Sienna Kit # 1 (Ferrule Kit) | 1 (as required) |
| 04000-40208 | Sienna Kit # 2 (Lift Plate Kit) | 1 (as required) |

2004 – 2006 Sienna Vehicles

| Part Number | Part Description | Quantity |
|-------------|---------------------------------|-----------------|
| 04000-41145 | Floor Seal Kit | 1 |
| 04000-40108 | Sienna Kit # 1 (Ferrule Kit) | 1 (as required) |
| 04000-40208 | Sienna Kit # 2 (Lift Plate Kit) | 1 (as required) |

The parts information above is designed to be a quick reference for your convenience. Additional Parts information can be found in the Appendix.

IMPORTANT PARTS ORDERING REMINDER

Effective March 1, 2009, Safety Recall, Service Campaign (SSC/LSC) and Customer Support Program (CSP) parts do not earn Parts Return Credit Accrual and are not returnable under the Monthly Return Program. It is recommended that you order these parts based on appointments or immediate customer needs using a "Sell One-Buy One" ordering pattern. Please refer to PANT Bulletin 09-12 for additional details.

7. Warranty Processor Instructions

Please note the following for this Special Service Campaign:

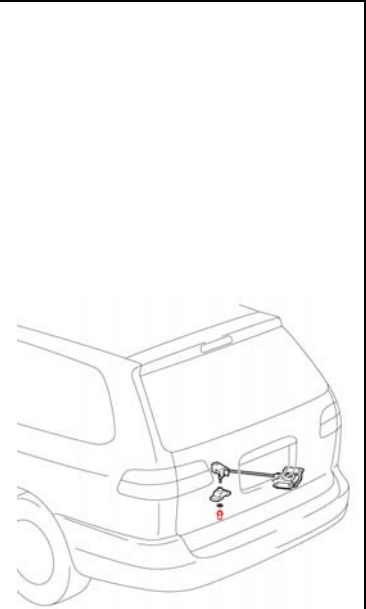

Dealers located in the states covered by this SSC should not solicit opportunities to perform this campaign. Any abuse or misuse of this SSC will result in the dealer being debited.

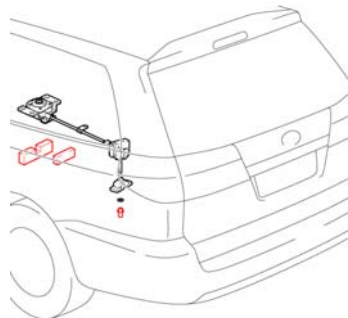

1998 – 2003 Model Year Sienna

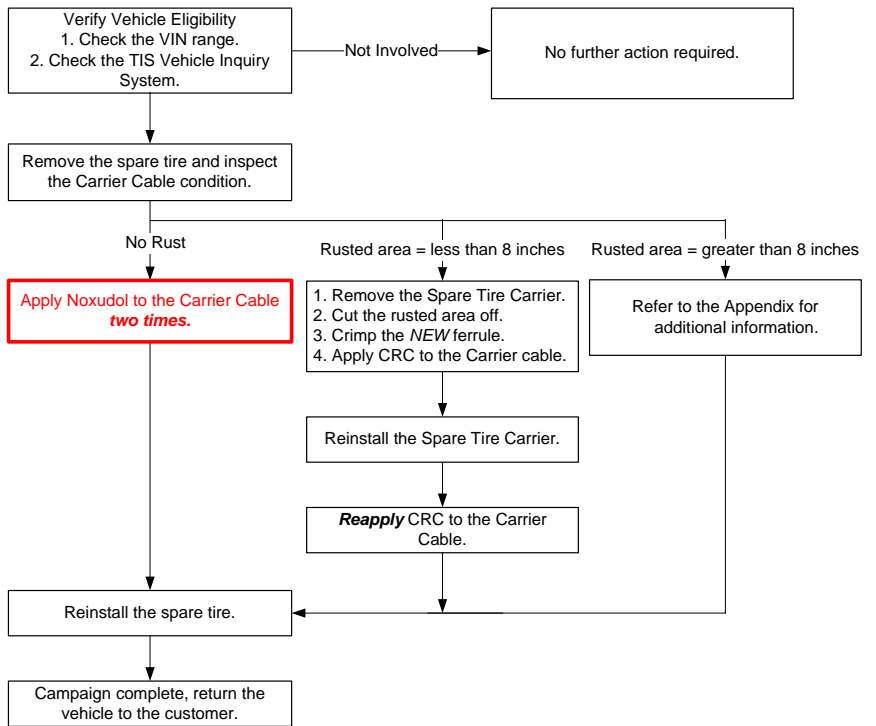

2004 – 2006 Model Year Sienna

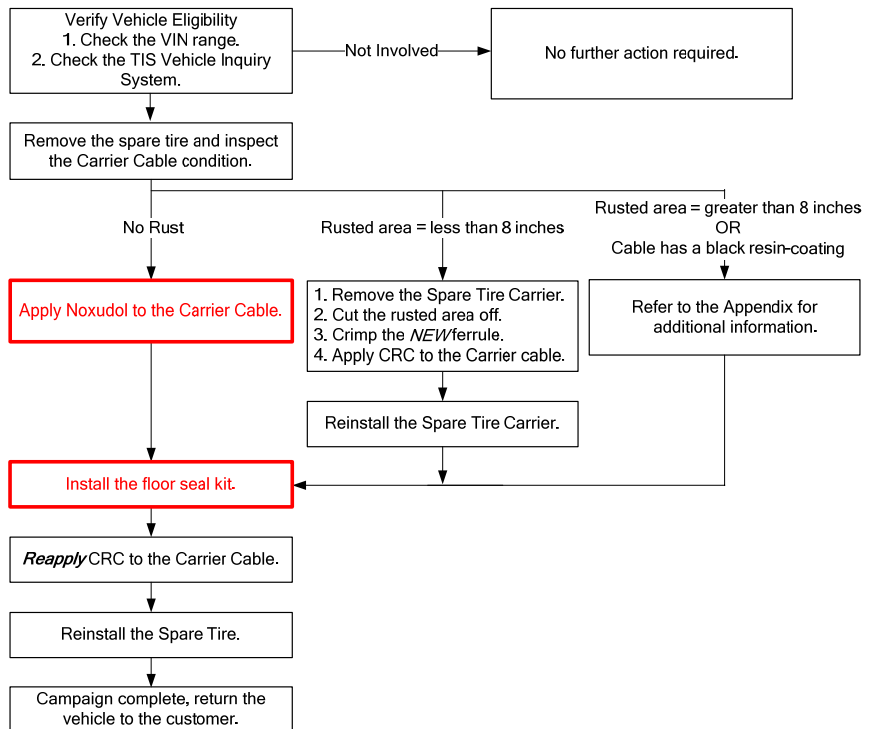

(Warranty Processor Instructions Continued . . .)

1998 – 2003 Model Year Sienna Vehicles

| SSC # | Op. Code | Description | Flat Rate Hour |
|-------|----------|---|----------------|
| A7E | 0522JE | <ul style="list-style-type: none"> Inspect the Spare Tire Carrier Cable – Inspection OK Apply CRC to the Spare Tire Carrier Cable | 0.5 hr/vehicle |
| | 0522JF | <ul style="list-style-type: none"> Inspect the Spare Tire Carrier Cable – Inspection NG Repair the Spare Tire Carrier Cable Apply CRC to the Spare Tire Carrier Cable | 0.7 hr/vehicle |

2004 – 2006 Model Year Sienna Vehicles

| SSC # | Op. Code | Description | Flat Rate Hour |
|-------|----------|---|----------------|
| A7E | 0522JH | <ul style="list-style-type: none"> Inspect the Spare Tire Carrier Cable – Cable OK Apply CRC to the Spare Tire Carrier Cable Install floor seal | 0.5 hr/vehicle |
| | 0522JJ | <ul style="list-style-type: none"> Inspect the Spare Tire Carrier Cable – Cable NG Repair the Spare Tire Carrier Cable Apply CRC to the Spare Tire Carrier Cable Install floor seals | 0.8 hr/vehicle |

- The above flat rate times include 0.1 hours for administrative cost per unit for the dealership.
- The cost for the Noxudol 300® (CRC) can be claimed as a sublet type “OF” at a rate of \$2.00 per vehicle.

8. Customer Handling

Customers who receive the owner letter may contact your dealership with questions regarding the letter and/or SSC remedy. Please welcome them to your dealership and answer any questions they may have. A Q&A is provided to assure a consistent message is communicated.

Customers with additional questions or concerns are asked to please contact the Toyota Customer Experience Center (1-888-270-9371).

9. Media Contacts

For **News media inquiries only**:

It is imperative that all media contacts (local and national) receive a consistent message. In this regard, **all media contacts** must be directed to Brian Lyons (310) 468-2552, in Corporate Communications. (Please do not provide these numbers to customers or direct dealership associates to call).

Please review this entire package with your Service and Parts staff to familiarize them with the proper step-by-step procedures required to implement this SSC.

Thank you for your cooperation.
TOYOTA MOTOR SALES, U.S.A., INC.

APPENDIX

The necessary parts can be ordered through your dealership's facing PDC. Please refer to the table below and the Technical Instructions (located on TIS) for part number information.

2004 – 2006 Sienna Vehicles

| Part Number | Part Description | Quantity |
|---|------------------|--------------------|
| 04000-41145 | Floor Seal Kit | 1 (2004 – 2006 MY) |
| <p>The kit above includes the following parts: 57899-45020 = Long Floor Seal (Seal, RR Floor) = 1 58212-45011 = Short Floor Seal (Seal, CTR Floor) = 2</p> <p><i>A Floor Seal Kit is required for all 2004-2006 model year Sienna vehicles equipped with a spare tire.</i></p> | | |

1998 – 2006 Sienna Vehicles

| Part Number | Part Description | Quantity |
|--|------------------------------|-----------------|
| 04000-40108 | Sienna Kit # 1 (Ferrule Kit) | 1 (as required) |
| <p>The kit above includes the following parts: 51923-08010* = Plate, Spare Tire Wheel Carrier Hanger = 1 51946-08010* = Bracket, Spare Wheel Carrier Stopper = 1 90080-17258 = Nut, Flange = 6</p> <p><i>A Ferrule Kit should only be installed if the spare tire carrier cable exhibits a rust condition that is less than 8". Refer to the TI located on TIS for additional information.</i></p> | | |

*These parts are NOT available as individual service parts.

1998 – 2006 Sienna Vehicles

| Part Number | Part Description | Quantity |
|---|---------------------------------|-----------------|
| 04000-40208 | Sienna Kit # 2 (Lift Plate Kit) | 1 (as required) |
| <p>The kit above includes the following parts: 51938-08020* = Bracket, Spare Wheel Carrier Mounting (Lift Plate) = 1 51945-08020* = Bracket, Spare Wheel Carrier Cushion (Bushing) = 1</p> <p><i>A lift plates should only be replaced if there is severe rust on the lift plate, damage to the bushing, and/or no paint left on the lift plate. Refer to the TI located on TIS for additional information.</i></p> | | |

*These parts are NOT available as individual service parts.

IMPORTANT PARTS ORDERING REMINDER

Effective March 1, 2009, Safety Recall, Service Campaign (SSC/LSC) and Customer Support Program (CSP) parts do not earn Parts Return Credit Accrual and are not returnable under the Monthly Return Program. It is recommended that you order these parts based on appointments or immediate customer needs using a "Sell One-Buy One" ordering pattern. Please refer to PANT Bulletin 09-12 for additional details.

(Appendix Continued . . .)

In a limited number of cases, it may be necessary to replace the spare tire carrier assembly. **Refer to TIS for replacement qualifications.** The following part and Op. Code tables are provided for your reference.

| Make | Part Number | Description | Qty per Vehicle |
|---|--------------|--|-----------------|
| 1998-2003 Model Year Sienna (Gen 1) | 51900-08010 | Carrier Assy, Spare Tire | 1 (as required) |
| 2004-2010 Model Year Sienna (Gen 2) | 51900-08034* | Carrier Assy, Spare Tire | 1 (as required) |
| 2004 Through Certain 2008 Model Year Sienna | 51942-28010* | Spare Wheel Carrier Bolt Socket Handle | 1 (as required) |
| | 51939-45010* | Spare Wheel Carrier Lock Cover | 1 (as required) |
| | 74544-08120* | Tire Carrier Notice Label | 1 (as required) |

* Second generation 2WD Sienna vehicles produced before mid-February 2008 may be equipped with a spare tire carrier assembly utilizing a hexagon (6-sided ☉) type spare tire clamp bolt. The replacement carrier will be equipped with a pentagon (5-sided ☉) type clamp bolt. When installing a new spare tire carrier assembly that utilizes a pentagon type bolt, dealers will need to make sure the vehicle is equipped with a Spare Tire Wheel Carrier Bolt Socket, Spare Wheel Carrier Lock Cover and the Tire Carrier Notice Label on the vehicles. Please refer to T-SB-0381-08 for additional information.

Manual Allocation Control (MAC) for Spare Tire Carrier Assemblies:

In a limited number of cases, it may be necessary for the dealer to replace the spare tire carrier assembly. To help ensure a sufficient quantity of parts, the spare tire carrier assembly has been placed on Manual Allocation Control (MAC).

MAC parts are reviewed and released daily based on available inventory and specific dealer ordering criteria. Currently, spare tire carrier assemblies are reviewed and released daily by NAPO Special Activity team. Approval or special request from Dealer Operations is no longer required.

1998 – 2003 Model Year Sienna Vehicles

| SSC # | Op. Code | Description | Flat Rate Hour |
|-------|----------|---|----------------|
| A7E | 0522JG | <ul style="list-style-type: none"> Inspect the Spare Tire Carrier Cable – Cable NG Replace the spare tire carrier assembly Apply CRC to the new spare tire carrier cable | 0.5 hr/vehicle |

2004 – 2006 Model Year Sienna Vehicles

| SSC # | Op. Code | Description | Flat Rate Hour |
|-------|----------|--|----------------|
| A7E | 0522JK | <ul style="list-style-type: none"> Inspect the Spare Tire Carrier Cable – Cable NG Install floor seals Replace the spare tire carrier assembly | 0.6 hr/vehicle |



Refer to TIS for spare tire carrier assembly replacement qualifications.

- The above flat rate times include 0.1 hours for administrative cost per unit for the dealership.
- The cost for the Noxudol 300® (CRC) can be claimed as a sublet type “OF” at a rate of \$2.00 per vehicle.
- **CRC will only need to be applied to new spare tire carrier cables designed for 1998 – 2003 model year Sienna vehicles.**
- For cases where the spare tire is missing from the vehicle, due to rust corroding the cable, use the following formula for reimbursement. Sublet type **ZZ**:

Op Code 0522J3/0522JA + Tire & Rim Cost + Mounting of Tire on Rim (max. 0.4hr) + Valve Stem, Tire Weights, etc (max. \$10) =

**Certain 1998 Through 2010 Toyota Sienna Vehicles Equipped with a Spare Tire
Severe Corrosion of Spare Tire Carrier Cable
Special Service Campaign**

[VIN]

Dear Toyota Owners:

At Toyota, we are dedicated to providing vehicles of outstanding quality and value. As part of our continuing efforts to meet your product expectations, Toyota would like to announce a Special Service Campaign on certain 1998 - 2010 Model Year Sienna Vehicles equipped with a spare tire.

What is the condition?

This condition may occur if the subject vehicle is operated in cold climate regions of the United States where road salts are frequently used. Water can splash backwards with high concentrations of road salt, reach the spare tire carrier and corrode the spare tire carrier assembly cable.

This Special Service Campaign offers to apply a Corrosion Resistant Compound (CRC) to the end of the spare tire carrier cable on 1998 – 2010 model year Sienna 2WD vehicles (equipped with a spare tire carrier) if the owner believes his/her vehicle will be operated in areas where a high concentration of road salt is frequently applied.

What is included in this Special Service Campaign?

If you believe your vehicle will be operated in cold climate regions of the United States where high road salt is frequently used, any authorized Toyota Dealer will apply a Corrosion Resistant Compound (CRC) to the end of your vehicle's spare tire carrier cable at **NO CHARGE** to you.

Vehicles originally sold-in and currently registered in the following states as well as American Samoa, Guam, Puerto Rico and Saipan will receive this offer:

AK, AL, AR, AZ, CA, CO, FL, GA, HI, IA, ID, KS, LA, MO, MS, MT, NC, ND, NE, NM, NV, OK, OR, SC, SD, TN, TX, UT, WA, or WY

How do you take advantage of this Special Service Campaign?

If you believe your vehicle will be operated in cold climate regions of the United States where a high concentration of road salt is frequently applied, please contact an authorized Toyota Dealer and schedule an appointment to have a Corrosion Resistant Compound (CRC) applied to the end of your vehicle's spare tire carrier cable. The application of the CRC will take approximately thirty minutes. However, depending upon the dealer's work schedule, it may be necessary to make your vehicle available for a longer period of time.

If your vehicle is covered by this Special Service Campaign you do not need an owner letter to request that this campaign be conducted; however to assist the dealer in confirming vehicle eligibility, we request that you present this notice at the time of your service request.

If you would like to update your vehicle ownership or contact information, please go to www.toyota.com/ownersupdate. You will need your full 17-digit Vehicle Identification Number (VIN) to input the new information.

What if you have other questions?

Your local Toyota dealer will be more than happy to answer any of your questions and set up an appointment to perform this Special Service Campaign. If you require further assistance, you may contact the Toyota Customer Experience Center at 1-888-270-9371 Monday through Friday, 5:00 am to 6:00 pm, Saturday 7:00 am through 4:00 pm Pacific Time.

If you are a vehicle lessor, please assist us by forwarding this notice to the lessee.

We have sent this notice in the interest of your continued satisfaction with our products, and we sincerely regret any inconvenience this condition may have caused you.

Thank you for driving a Toyota.

Sincerely,
TOYOTA MOTOR SALES, U.S.A., INC.



**Special Service Campaign A7E – Phase 1 (1998 through 2006 model year)
Certain 1998 through 2010 Toyota Sienna 2WD Vehicles Equipped with a Spare Tire
Severe Corrosion of Spare Tire Carrier Cable**

This SSC will be launched in phases consistent with the age of the vehicle. Phase 1 will cover 1998 – 2006 model year Sienna vehicles. Subsequent phases will include the remaining Sienna vehicles covered by this SSC (2007 – 2010 model year):

- Phase 1: Certain 1998 through 2006 Model Year Sienna 2WD vehicles
- Phase 2: Certain 2007 through 2009 Model Year Sienna 2WD vehicles
- Phase 3: Certain 2010 Model Year Sienna 2WD vehicles

Q1: What is the condition?

A1: This condition may occur if the subject vehicle is operated in cold climate regions of the United States where road salts are frequently used. Water can splash backwards with high concentrations of road salt, reach the spare tire carrier and corrode the spare tire carrier assembly cable.

Q2: Are there any warnings this condition exists?

A2: No, there are no specific warnings that this condition exists.

Q3: What is the cause of this condition?

A3: The corrosion resistance of the spare tire carrier cable is insufficient when vehicles are operated in areas where a large amount of road salt is applied.

Q4: What is Toyota going to do?

A4: This SSC offers to apply* a Corrosion Resistant Compound (CRC) to the end of the spare tire carrier cable on certain 1998 – 2010 model year Sienna 2WD vehicles (equipped with a spare tire carrier) if the owner believes his/her vehicle will be operated in areas where high road salt is frequently used. Vehicles originally sold-in and currently registered in the following states and American Samoa, Guam, Puerto Rico and Saipan will receive this offer:

**AK, AL, AR, AZ, CA, CO, FL, GA, HI, IA, ID, KS, LA, MO, MS, MT, NC, ND, NE, NM, NV, OK,
OR, SC, SD, TN, TX, UT, WA, or WY**

**Based upon the inspection results, Toyota may need to repair the spare tire carrier cable prior to applying the CRC.*

Q4a: When will owners be notified?

A4a: Toyota will notify owners of covered vehicles by first class mail beginning in mid-November 2010

Q5: What should customers do?

A5: Owners of Sienna vehicles covered by this phase, who believe their vehicle will be operated in areas where high road salt is frequently used, may have Corrosion Resistant Compound (CRC) applied to the end of their vehicle's spare tire carrier cable.

Q6: Which and how many vehicles are involved in the Special Service Campaign?

A6: There are approximately 733,500 vehicles covered.

| Phase | Model Year | Model | Approx UIO |
|---------|-------------|------------|------------|
| Phase 1 | 1998 – 2006 | Sienna 2WD | 564,000 |
| Phase 2 | 2007 – 2009 | Sienna 2WD | 158,000 |
| Phase 3 | 2010 | Sienna 2WD | 11,500 |

Q7: Are there any other Toyota or Lexus vehicles involved?

A7: No other Toyota or Lexus vehicles are involved.

Q8: What is the production period of the Sienna vehicles covered by this Special Service Campaign?

A8: The vehicles covered by the Special Service Campaign were produced from August 1997 to January 2010.

Q9: How long will the remedy take?

A9: The CRC application and/or spare tire carrier cable repair will take approximately one hour. However, it may take longer based upon the inspection results and the dealer's work schedule.

Q10: What if a customer has previously paid to replace the vehicle's spare tire carrier for this specific condition?

A10: Reimbursement consideration instructions will be provided in the owner letter for those customers that have previously paid to replace the spare tire carrier cable for this specific condition.

Q11: What should an owner do if they experience the condition, or have immediate concerns about their vehicle?

A11: If an owner has any immediate concerns they are requested to contact their local Toyota dealer for diagnosis, and if applicable, necessary repair.

Owners may also contact the Toyota Customer Experience Center (1-800-331-4331) for additional assistance.