

**SUPPLEMENTAL TECHNICAL INSTRUCTIONS**  
**FOR**  
**LIMITED SERVICE CAMPAIGN C0D**

\* \* \* \* \*

**CERTAIN 2001-2004 MODEL YEAR SEQUOIA**

\* \* \* \* \*

**FRAME REPLACEMENT**

# I. OPERATION FLOWCHART

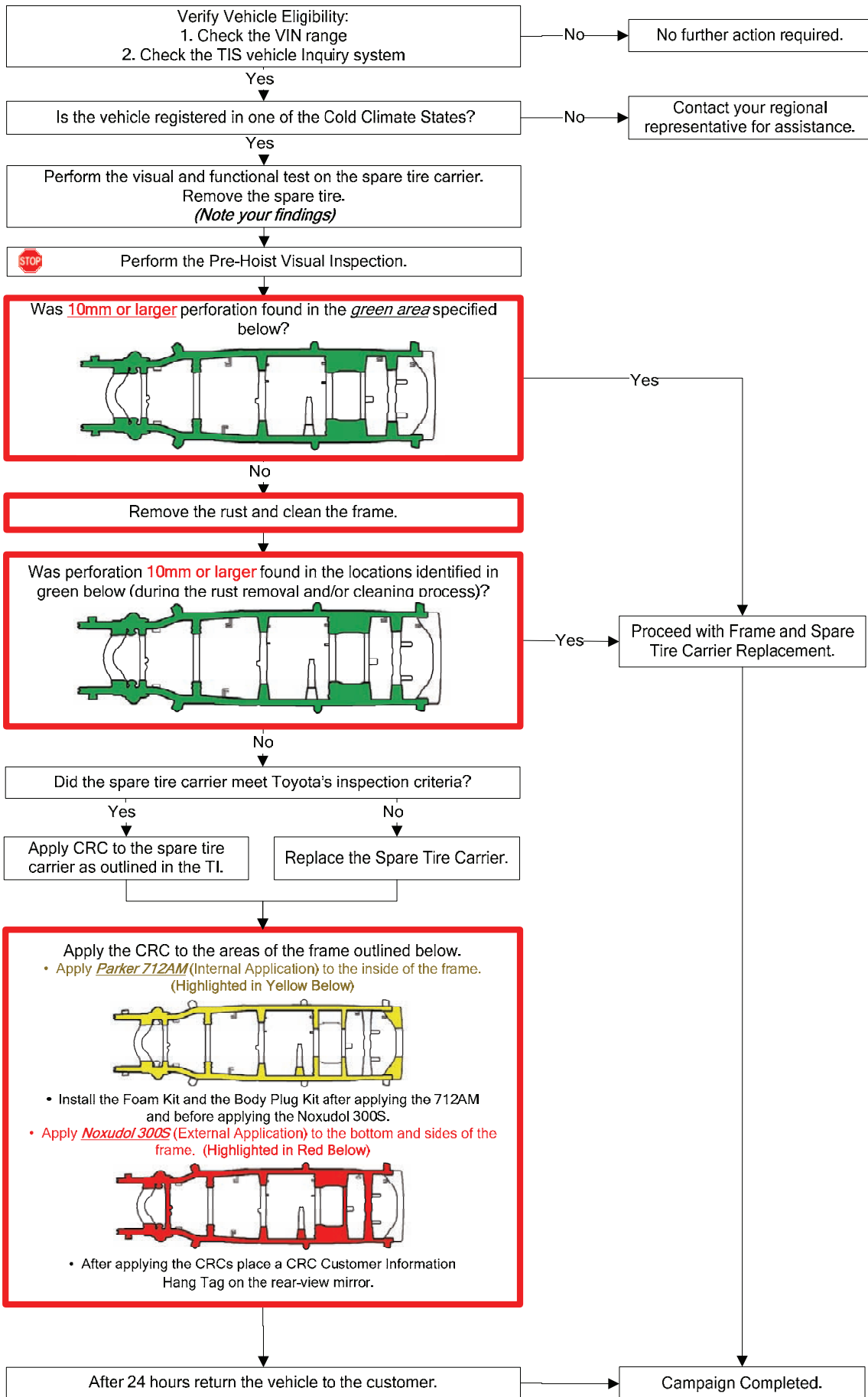

## II. PREPARATION

### A. TOOLS & EQUIPMENT

- **Above Ground Lift (Required)**
- Alignment Rack
- A/C Service Equipment with Manifold Gauges
- Brake Bleeder
- Cooling System Tester
- Engine Hoist (Qty: 2) or Hydraulic Mini Crane (Qty: 2)
- Engine Sling Device
- Floor Jack
- Protective Gloves
- Protective Eyewear
- Ratcheting Tie Down Strap (2 in X 27 ft, Minimum Work Load Capacity: 3,000 lbs)
- Standard Hand Tools
- Special Service Tools (SST)
  - 09325-40010 - Transmission Oil Plug
  - 09520-01010 - Drive Shaft Remover Attachment
  - 09520-32040 - Slide Hammer
  - 09610-20012 - Pitman Arm Puller
  - 09617-24011 - Steering Rack Wrench or Equivalent
  - 09628-62011 - Ball Joint Puller
  - 09922-10010 - Variable Open Wrench
- Techstream
- Torque Wrench

### B. SUPPLIES

- ATF D-II or DEXRON®III (DEXRON®II) – As needed
- Hypoid Gear Oil API GL-5 SAE 75W-90 – 1.15 liter (4WD Only, Front Differential)
- MP Grease
- Marker
- ND-OIL 8 Compressor Oil – As needed
- R134a Refrigerant – As needed
- Silicon Lubricant
- Toyota DOT 3 Brake Fluid – 3 pints
- Toyota Long Life Coolant – 2 gallons
- Vinyl Tape

## C. PARTS

To assist dealers in determining the correct part number(s) to order, a website has been set up to look up part numbers by VIN. Please go to <http://c0d-lookup.imagespm.info>, enter the VIN, and the correct part numbers to order will be displayed. **The website is for part(s) application reference only and will not order the part, nor will it confirm campaign completion status.**

- The parts will need to be ordered through the Dealer Daily Parts system.
- ETAs for the parts will be available via the normal system.
- Frame ETAs will be made available on the Dealer Daily website, in the MAC reference area.

An illustration of the parts replaced and their location(s) have been provided. Please reference the "**Illustration Name**" and "**Page**" columns in the parts tables below.

### Individual Parts:

Part Number	Part Description (Model Year)	Quantity	Illustration Name	Page
04001-7510C	Frame, Sub-Assy (01-02)	1	Frame & Misc Parts	6
04001-7520C	Frame, Sub-Assy (03-04)	1	Frame & Misc Parts	6
04001-7530C	Frame, Sub-Assy (01-02 w/Towing Hitch)	1	Frame & Misc Parts	6
04001-7540C	Frame, Sub-Assy (03-04 w/Towing Hitch)	1	Frame & Misc Parts	6

### Individual Parts (Continued):

Part Number	Part Description (Model Year)	Quantity	Illustration Name	Page
12157-10010	Gasket, Drain Plug	1	Front Differential	10
43425-04020	Ring, Drive Shaft Snap	2	Front Suspension & Front Driveshaft	8
47316-0C040	Tube, FR Brake, No.6	1	Brake Tubes	9
47322-0C030	Tube, RR Brake, No.2	1	Brake Tubes	9
47323-0C020	Tube, RR Brake, No.3	1	Brake Tubes	9
47325-0C020	Tube, RR Brake, No.5	1	Brake Tubes	9
47326-0C020	Tube, RR Brake, No.6	1	Brake Tubes	9
51900-0C020	Carrier, Spare Tire	1	Spare Tire Carrier	6
90080-43034	Gasket, Exhaust Pipe (01-02)	2	Exhaust System	12
90430-24003	Gasket	1	Front Differential	10
90917-06083	Gasket, Exhaust Pipe (03-04)	2	Exhaust System	12
95381-04045	Pin, Cotter	2	Front Suspension & Front Driveshaft	8

**Parts Kits:**

Part Number	Part Description	Quantity
04001-7010C	Parts Kit No.1 – Common Replacement kit A-1 (01-04MY)	1

**The kit listed above includes the following parts:**

Part Number	Part Description	Qty	Illustration	Page
16492-21050	Ring, O Radiator	1	Radiator	13
18495-38020	Retainer, Converter RR Flange	2	Exhaust System	12
23232-41081	Gasket	1	Fuel System	12
47351-34040	Bracket, Flexible Hose, No. 5	1	Brake Tubes	9
47353-35110	Bracket, Flexible Hose, No. 3	1	Brake Tubes	9
47354-35100	Bracket, Flexible Hose, No. 4	1	Brake Tubes	9
48409-34020	Cam Sub-Assy, Toe Adjust	2	Front Suspension & Front Driveshaft	8
48409-34030	Cam Sub-Assy, Toe Adjust	2	Front Suspension & Front Driveshaft	8
48452-35020	Plate, Toe Adjust, No. 2	4	Front Suspension & Front Driveshaft	8
48824-34030	Bracket Stabilizer RH	1	Front Suspension & Front Driveshaft	8
48829-34020	Bracket Stabilizer LH	1	Front Suspension & Front Driveshaft	8
77285-34031	Clamp, Fuel Tube, No. 1	5	Fuel Tubes	10
77285-34060	Clamp, Fuel Tube, No. 1	1	Fuel Tubes	10
77285-34080	Clamp, Fuel Tube, No. 1	1	Fuel Tubes	10
77285-34200	Clamp, Fuel Tube, No. 1	1	Fuel Tubes	10
90069-08009	Ring, O	1	Air Conditioning	13
90119-08516	Bolt, w/ Washer	10	Front Floor Panel & Front Floor Member	14
90178-08011	Nut, Flange	4	Rear Bumper	14
90178-10024	Nut, Flange	4	Front Bumper	13
90179-08054	Nut	1	Auto Trans Shaft Cable	13
90179-08068	Nut	6	Front Floor Panel & Front Floor Member	14
90179-10071	Nut	4	Engine Mounting	11
90719-14062	Nut	1	Rear Spring & Shock Absorber	7
90182-10004	Nut, w/ Washer	2	Front Suspension & Front Driveshaft	8
90201-09019	Washer, Plate	1	Auto Trans Shaft Cable	13
90252-03015	Pin, Cotter	2	Front Suspension & Front Driveshaft	8
90430-12026	Gasket	1	Fuel System	12
90460-22001	Clamp, Hose	2	Fuel Tank	13
90460-46005	Clamp, Hose	2	Fuel Tank	13
90468-08035	Clip	4	Brake Tubes	9
90904-12066	Way, 2	1	Brake Tubes	9
90904-12067	Way, 2	1	Brake Tubes	9
90904-12068	Way, 2	1	Brake Tubes	9
90917-06085	Gasket, Exhaust Pipe	1	Exhaust System	12
90949-01C06	Clamp	7	Brake Tubes	9
91621-B0816	Bolt, w/ Washer	6	Brake Tubes	9
94130-01232	Nut, Hexagon	6	Rear Bumper	14
94622-31200	Washer, Plate	6	Rear Bumper	14
95381-03225	Pin, Cotter	2	Power Steering	11

**Parts Kits (Continued):**

Part Number	Part Description	Quantity		
04001-7030C	Parts Kit No.3 – Common Replacement kit B-1 (01-04MY)	1		
<b>The kit listed above includes the following parts:</b>				
Part Number	Part Description	Qty	Illustration	Page
47313-0C012	Tube, FR Brake, No. 3	1	Brake Tubes	9
47314-0C011	Tube, FR Brake, No. 4	1	Brake Tubes	9
47317-0C011	Tube, FR Brake, No. 7	1	Brake Tubes	9
82164-0C040	Wire, Frame	1	Wire Harness Clamps	10
89542-0C010	Sensor, Speed, Front RH	1	ABS	11
89543-0C010	Sensor, Speed, Front LH	1	ABS	11
89545-0C020	Sensor, Speed, Rear RH	1	ABS	11
89546-0C020	Sensor, Speed, Rear LH	1	ABS	11
90069-08007	Ring, O	1	Air Conditioning	13
90080-11180	Bolt, w/ Washer	4	Rear Spring & Shock Absorber	7
90080-11180	Bolt, w/ Washer	4	Spare Wheel Carrier	6
90080-11180	Bolt, w/ Washer	2	Fuel Tubes	10
90080-11275	Bolt, w/ Washer	2	Front Suspension & Front Driveshaft	8
90080-11373	Bolt, w/ Washer	5	Suspension Crossmember & Under Cover	6
90080-11373	Bolt, w/ Washer	5	Fuel Tank	13
90080-11387	Bolt, w/ Washer	4	Engine Mounting	11
90080-11410	Bolt, w/ Washer	2	Front Suspension & Front Driveshaft	8
90080-11482	Bolt, w/ Washer	2	Front Suspension & Front Driveshaft	8
90080-11482	Bolt, w/ Washer	4	Rear Spring & Shock Absorber	7
90080-11491	Bolt, w/ Washer	6	Frame & Misc. Parts	6
90080-11492	Bolt, w/ Washer	4	Frame & Misc. Parts	6
90080-11555	Bolt, w/ Washer	2	Power Steering	11
90080-46263	Clamp	1	Exhaust System	12
90069-08009	Ring, O	1	Air Conditioning	13
90119-A0026	Bolt, w/ Washer	4	Rear Bumper	14
90119-A0027	Bolt, w/ Washer	2	Rear Bumper	14
90119-A0064	Bolt, w/ Washer	4	Rear Bumper	14
90119-A0077	Bolt, w/ Washer	2	Fuel Tank	13

## D. PARTS ILLUSTRATION

### Frame & Misc Parts

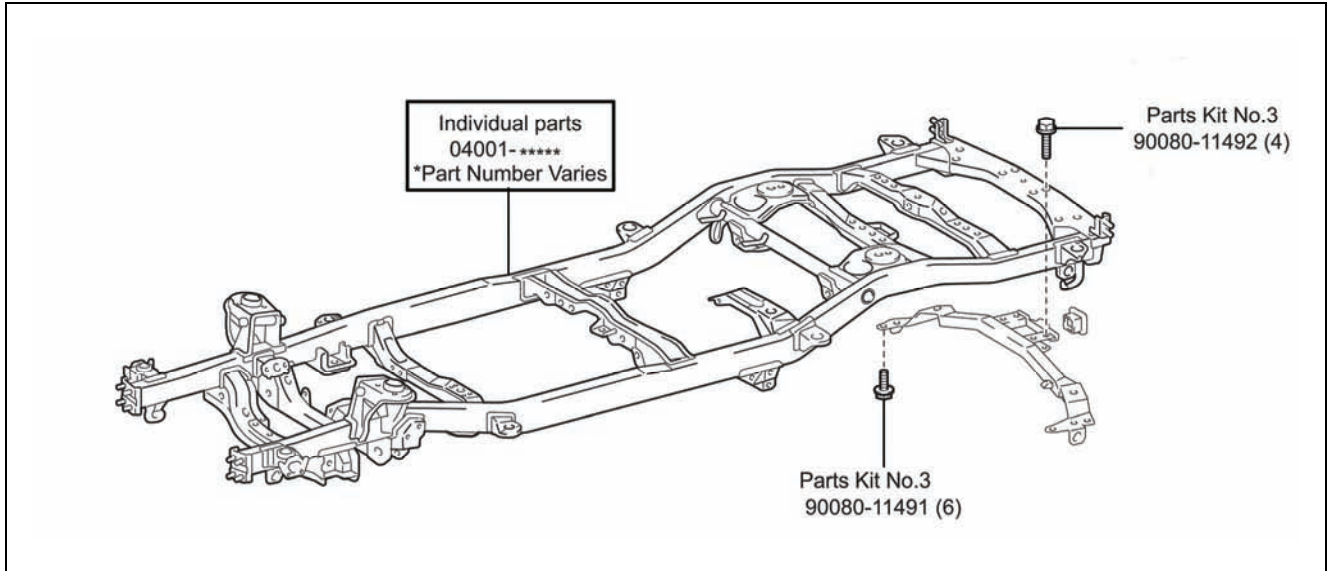

### Suspension Crossmember & Under Cover

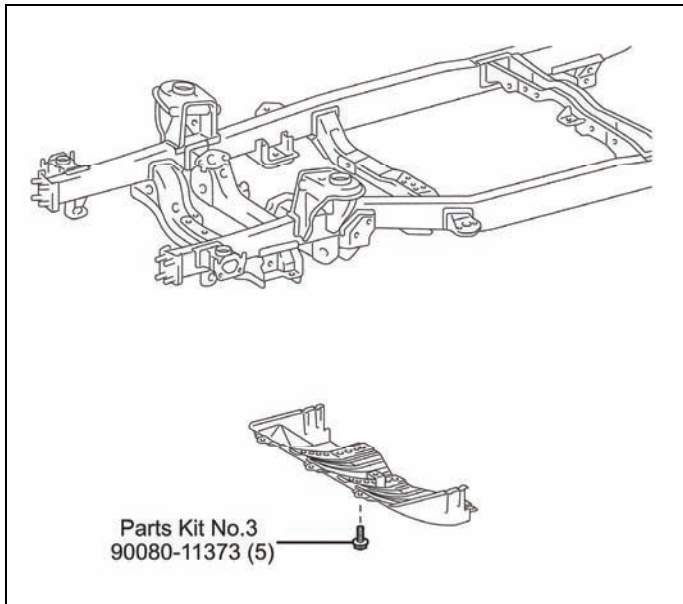

### Spare Tire Carrier

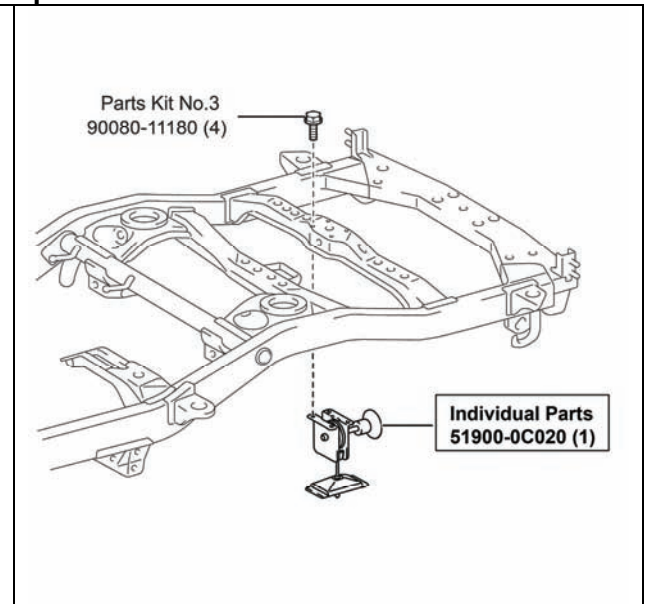

# Rear Spring & Shock Absorber

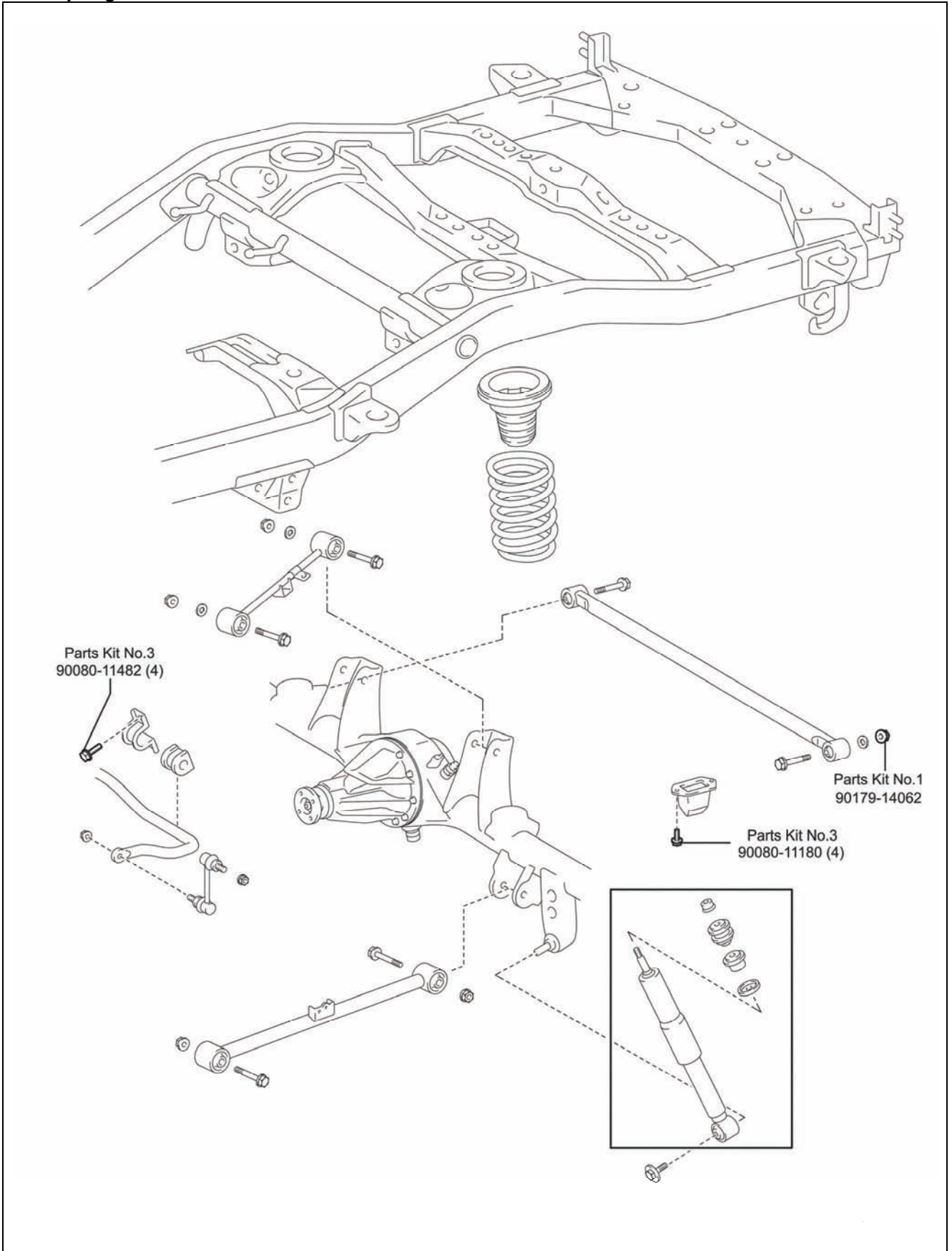







## Fuel Tubes

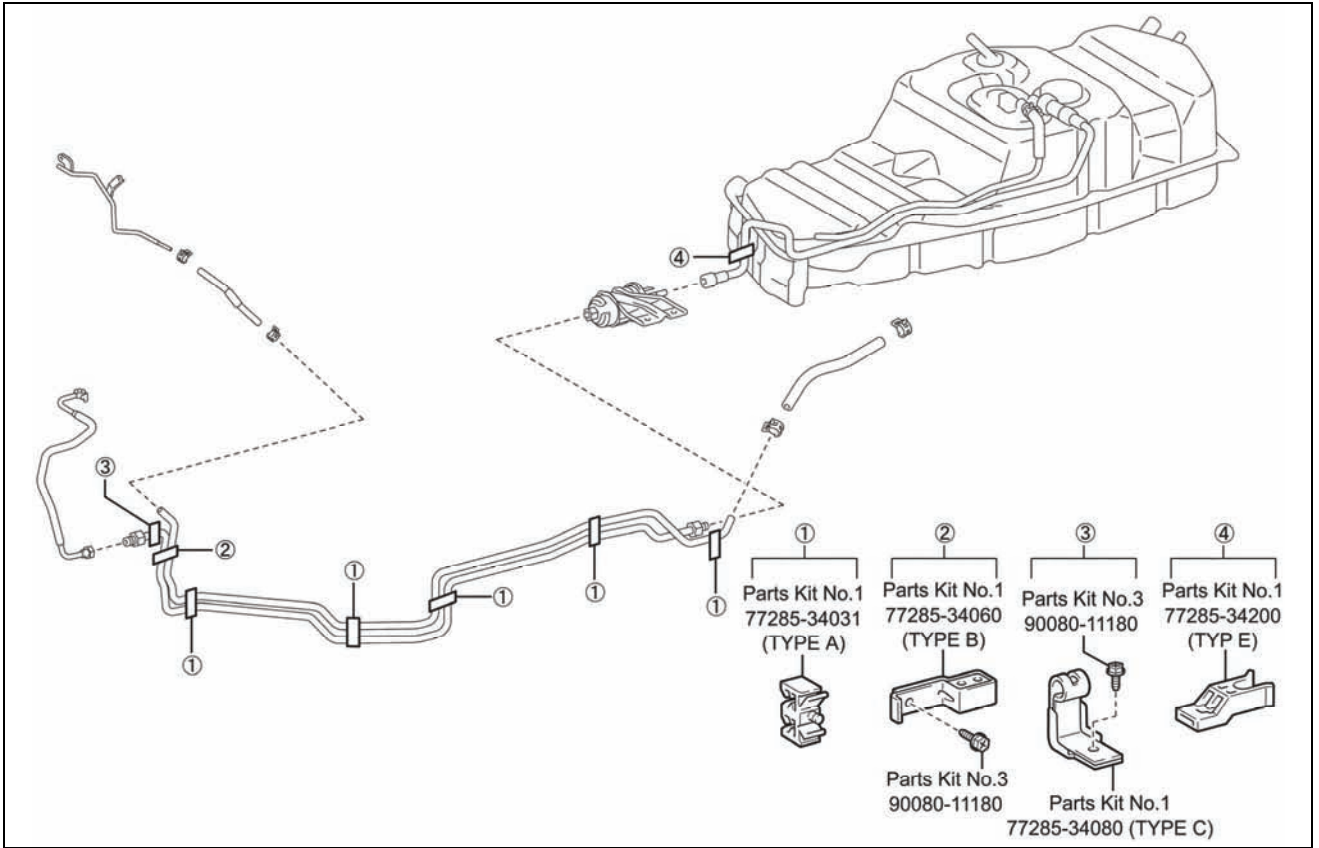

## Wire Harness Clamps

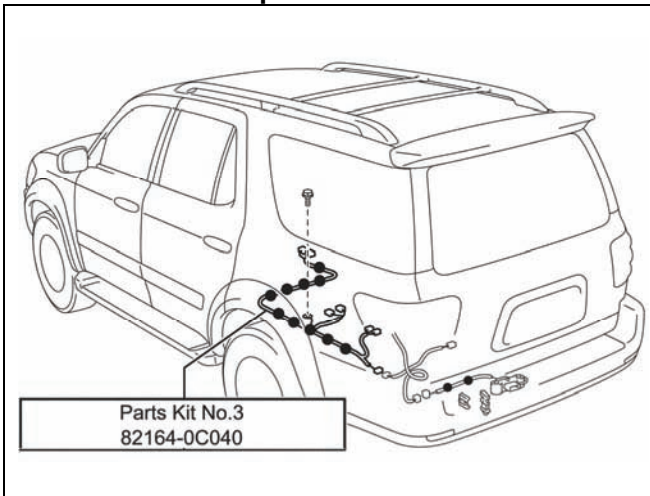

## Front Differential

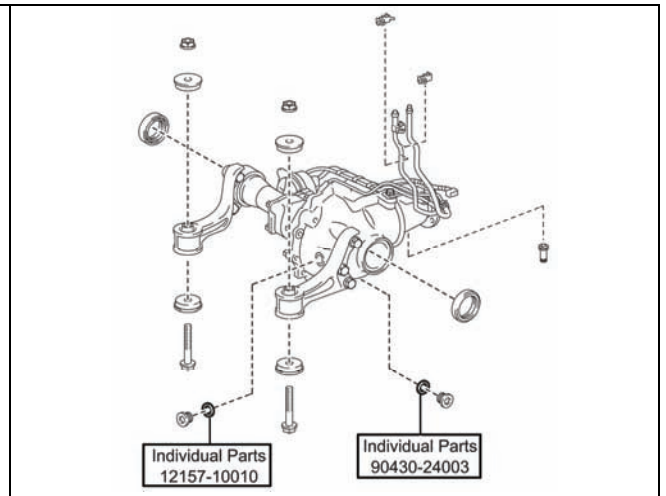

## Power Steering

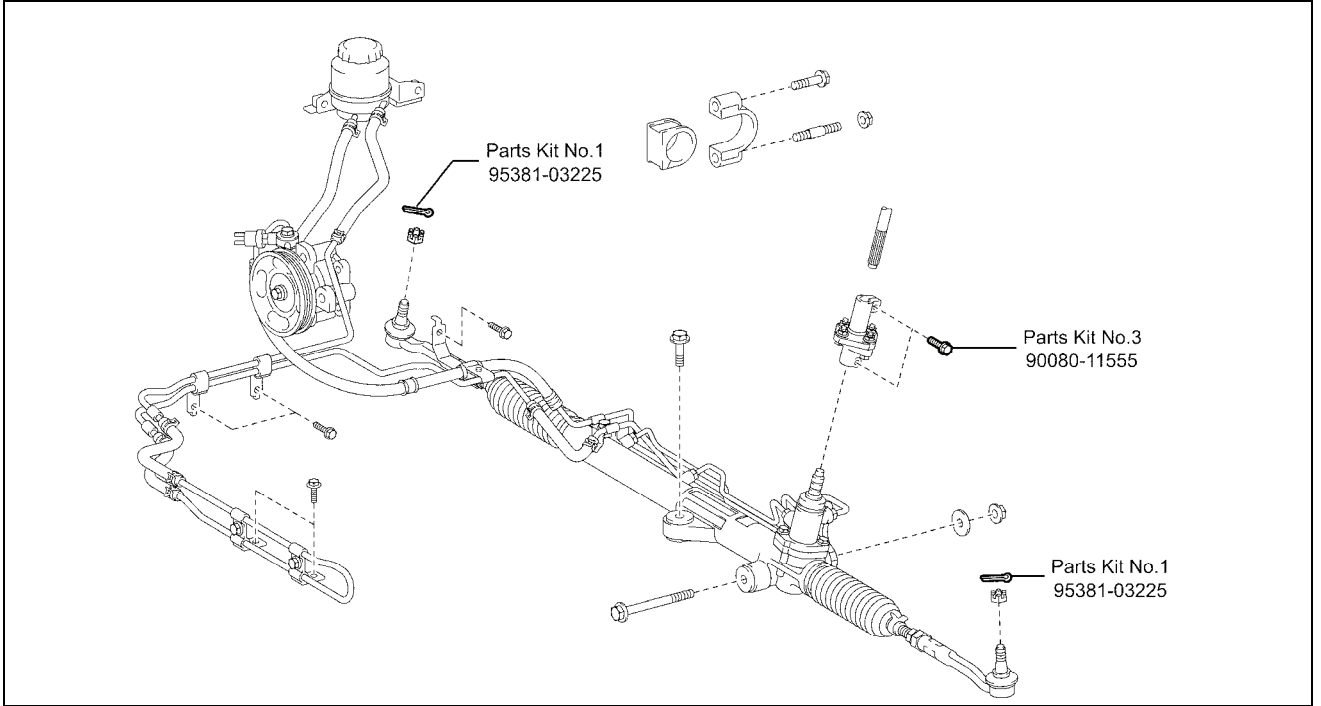

## ABS

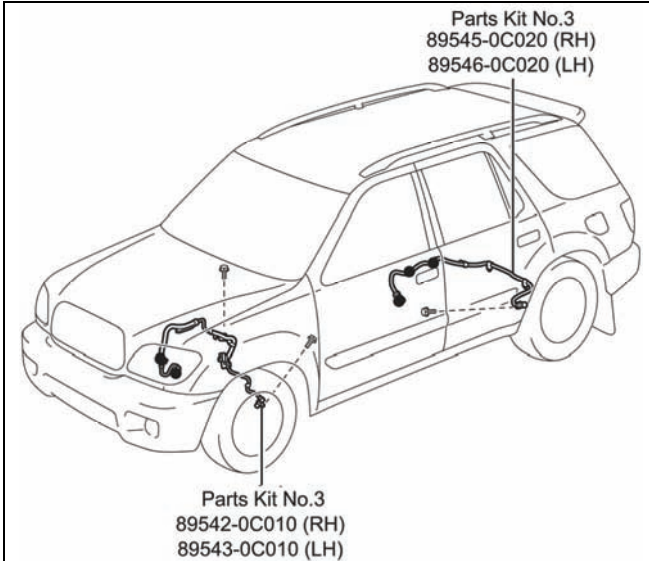

## Engine Mounting

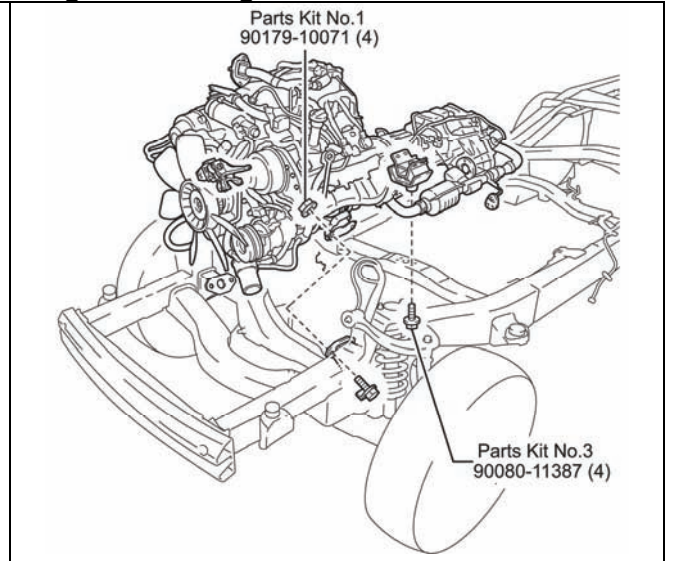

## Fuel System

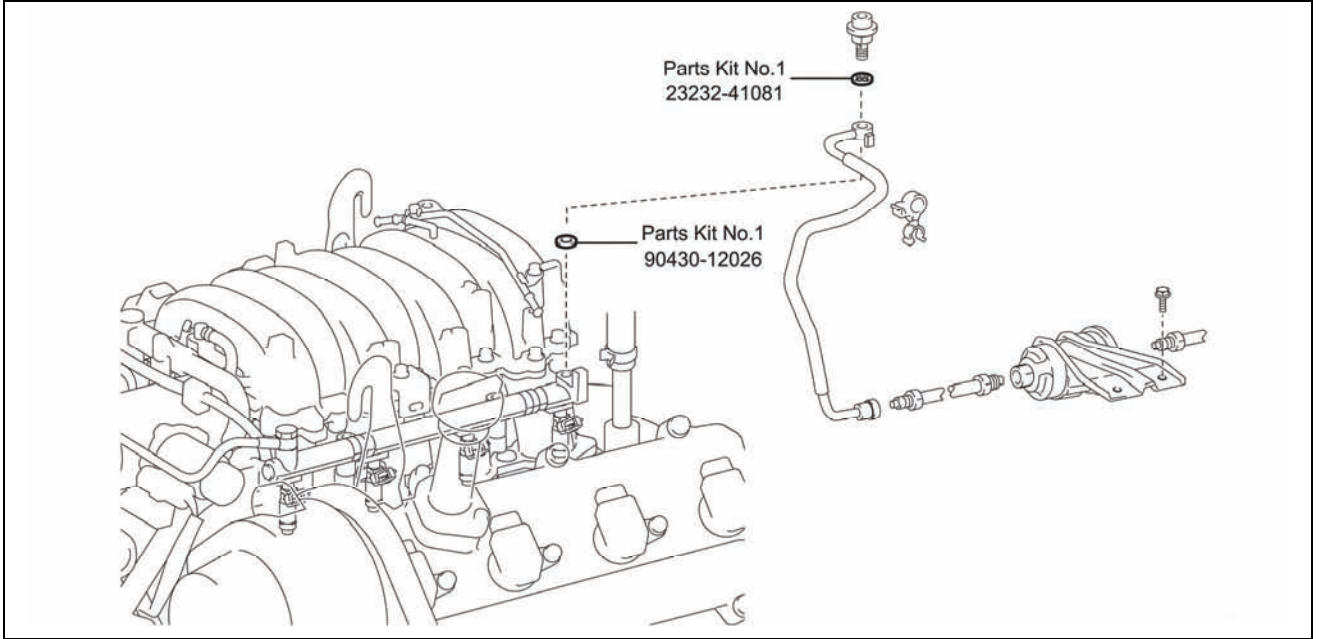

## Exhaust System

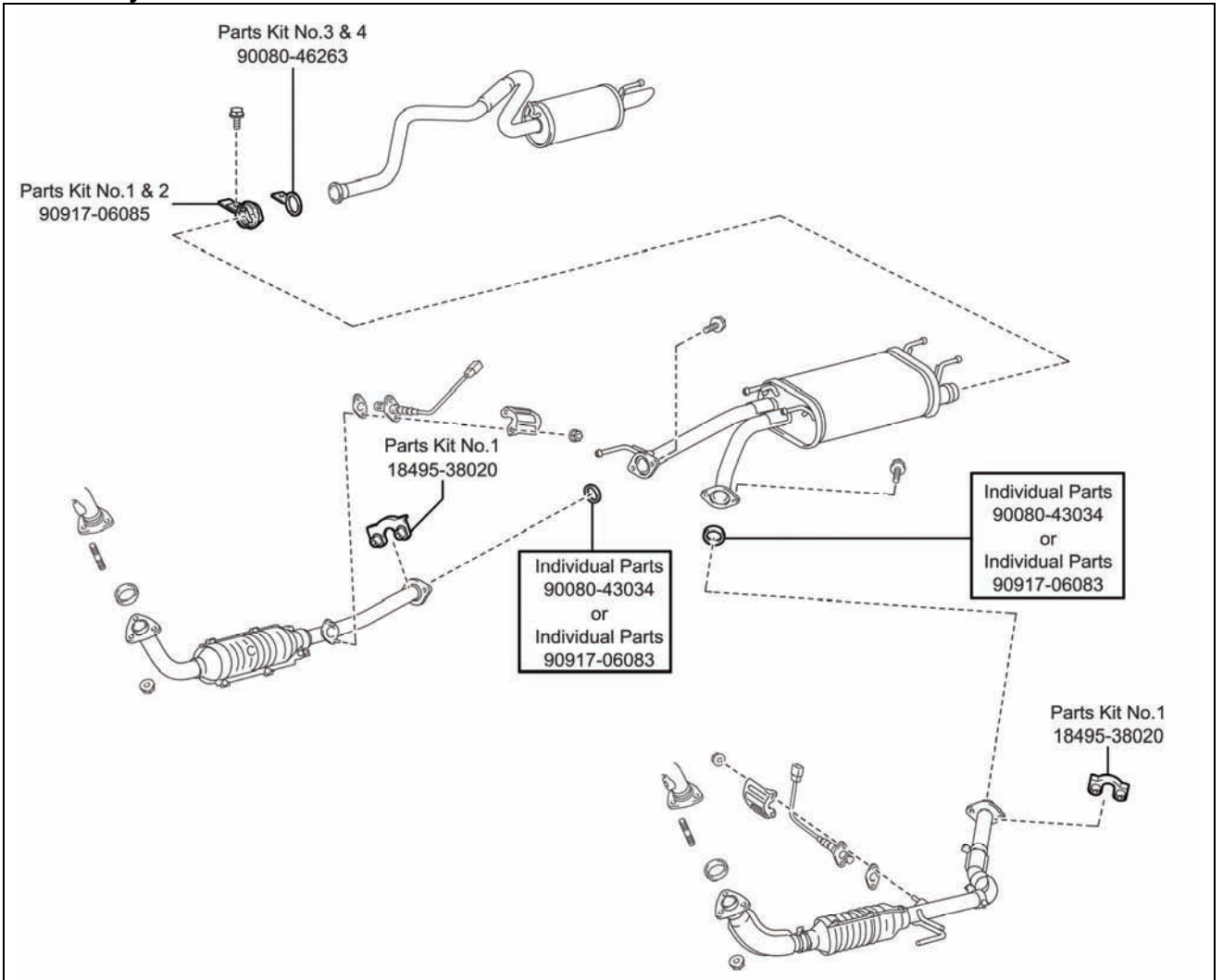

## Fuel Tank

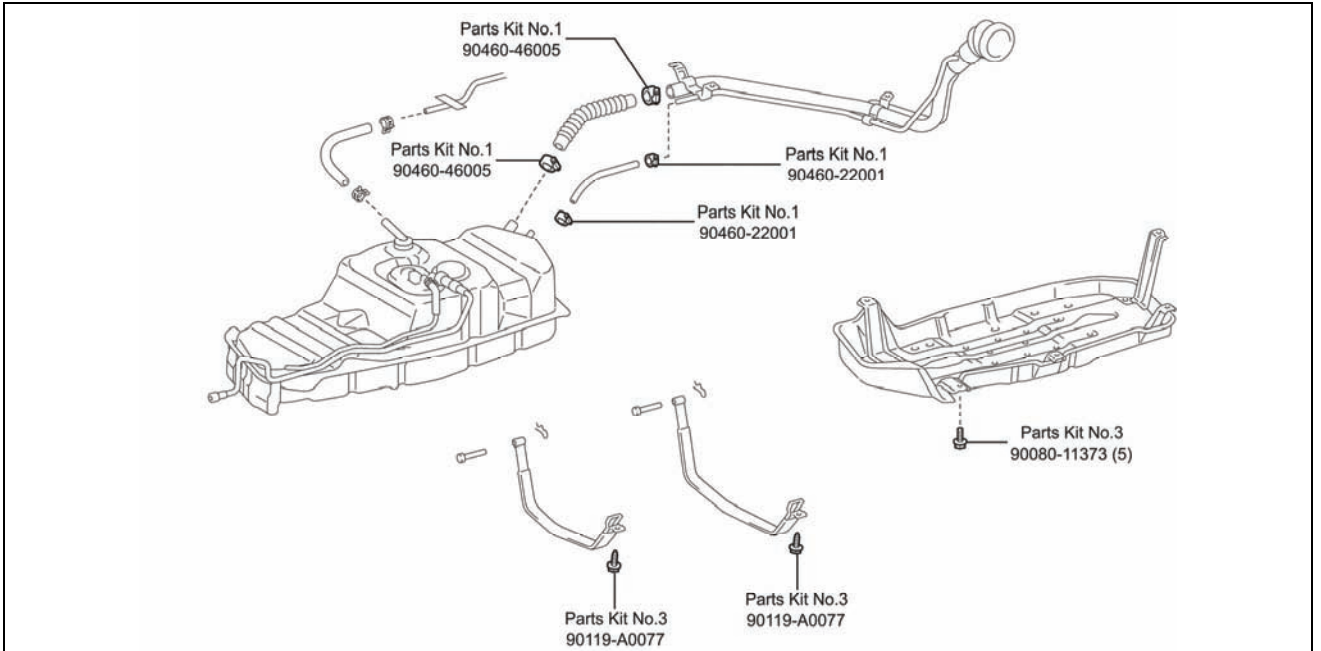

## Air Conditioning

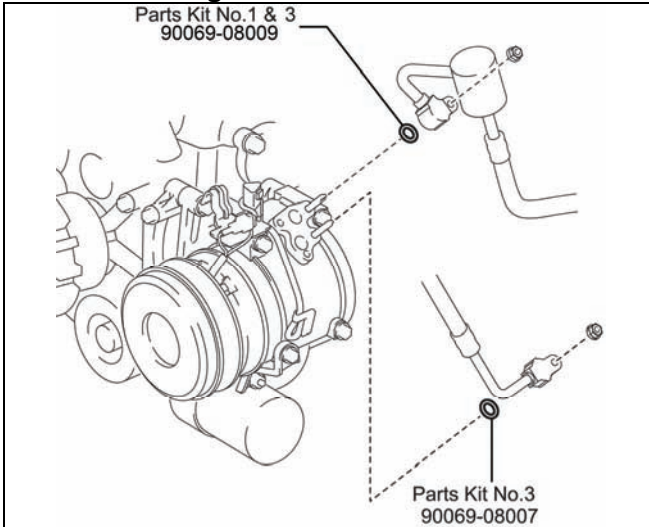

## Auto Trans Shift Cable

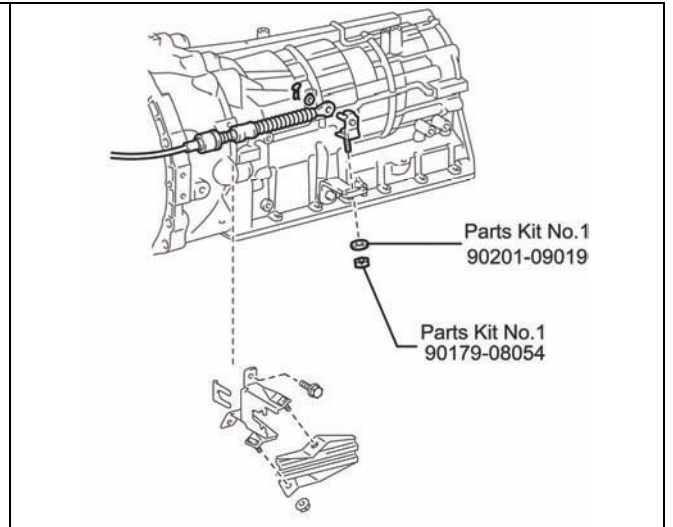

## Radiator

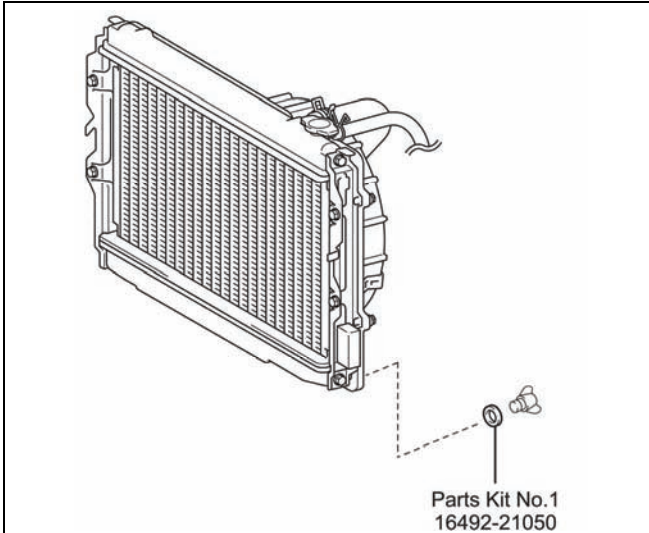

## Front Bumper

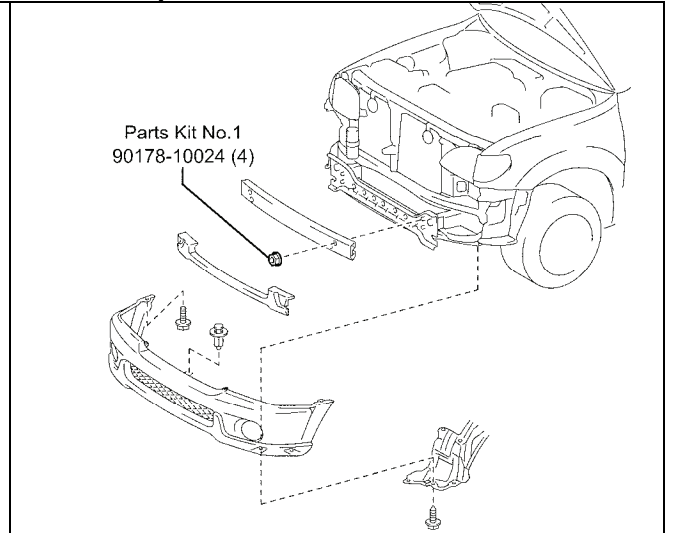

## Rear Bumper

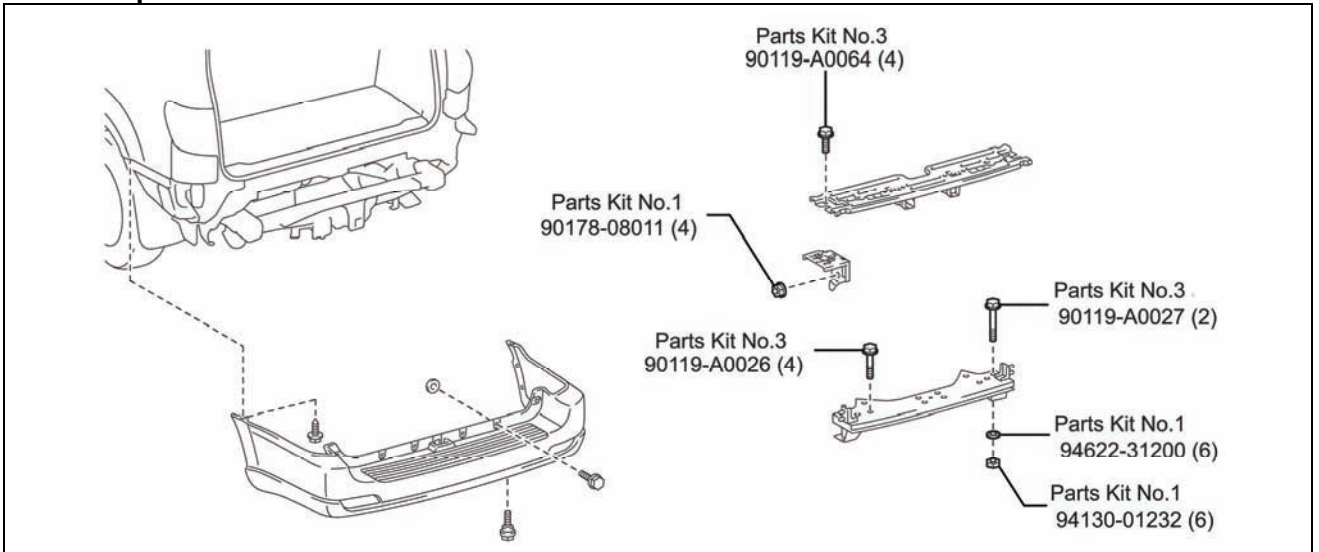

## Front Floor Panel & Front Floor Member

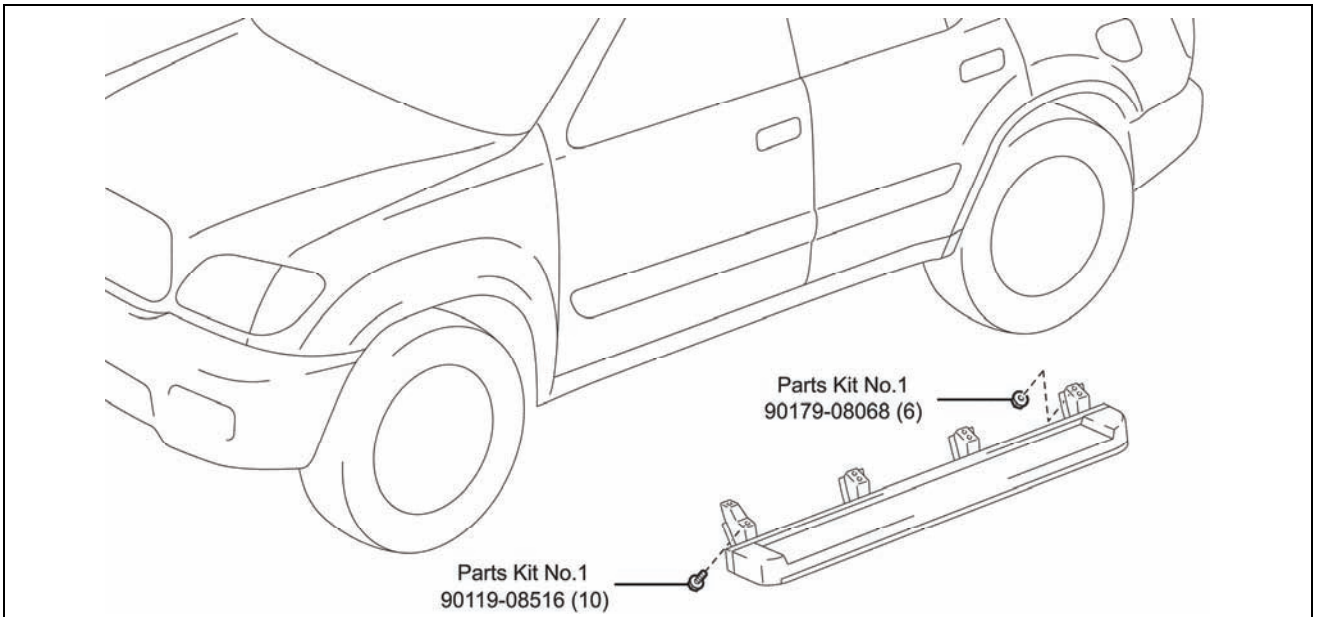

### III. VEHICLE INSPECTION WORK PROCEDURE

#### A. FUNCTIONAL AND VISUAL INSPECTION OF THE SPARE TIRE CARRIER

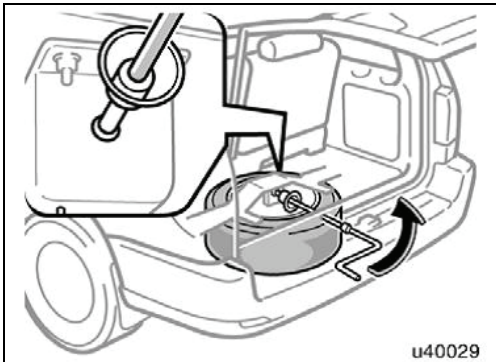

u40029

#### 1. FUNCTIONAL TEST OF THE SPARE TIRE CARRIER

- a) Lower and raise the spare tire with the tools provided with the vehicle and ensure it is operating properly.

**Note: Do not operate the spare tire carrier with an impact because damage will occur to the spare tire carrier.**

- b) Completely lower the spare tire and remove it from the carrier

#### 2. VISUALLY INSPECT THE SPARE TIRE CARRIER PLATE FOR RUST CORROSION

- a) Visually inspect the top and bottom of the spare tire carrier plate for rust corrosion as shown below.



**If rust is not obvious, proceed to next step.**



**NG**

- b) Inspect the top center portion (40 mm diameter circle) of the spare tire carrier plate for rust corrosion and confirm it contains less than 80% rust.

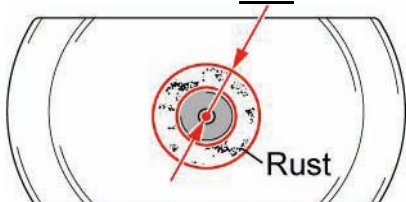

**Proceed to next step**

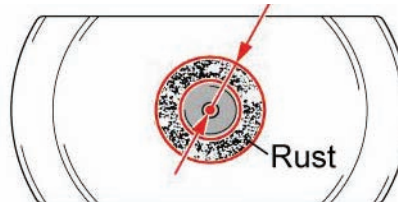

**NG**

- c) Inspect the bottom edge of the spare tire carrier plate for rust corrosion around the perimeter; confirm that rust corrosion does not cover the entire perimeter.

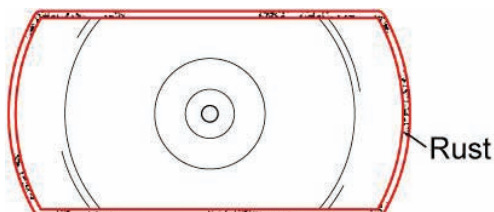

**OK**

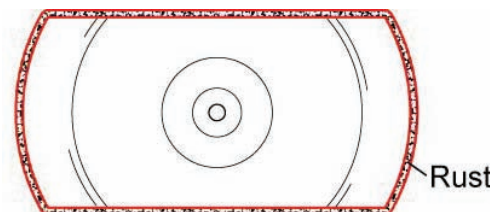

**NG**

**NG**

- If the spare tire carrier does not pass any of the inspection criteria, the spare tire carrier will need to be replaced.
- If the frame does not pass the inspection (below) and requires replacement, the carrier is included in the parts supplied for the frame replacement.



## 1. PERFORM INITIAL PRE-HOIST INSPECTION

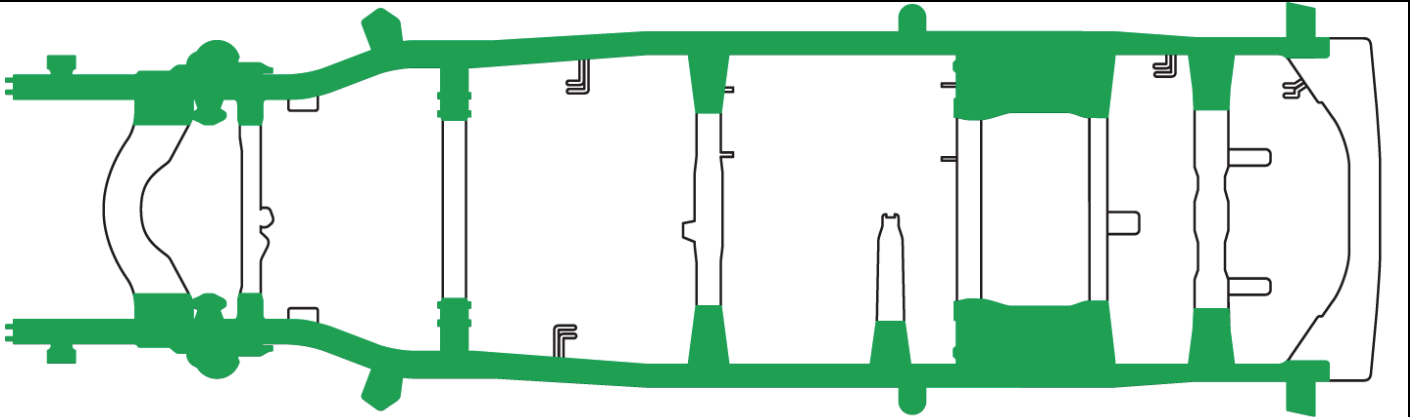

## 2. VISUALLY INSPECT THE FRAME

- a) Visually inspect the specific areas (highlighted in **green**) of the frame assembly as shown for visible signs of perforation.

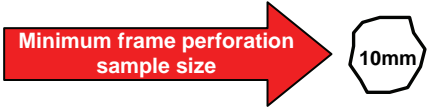
Judgment Criteria	Result	Action
Perforation (hole) of <b>10</b> mm or more 	NG	<ul style="list-style-type: none"> <li>Replace the frame and spare tire carrier</li> <li>Proceed to section <b>IV. VEHICLE CONDITION INSPECTION</b> below to begin the frame replacement process.</li> </ul> <p><b>Note: If the frame fails the inspection the spare tire carrier will be replaced automatically.</b></p>
Perforation (hole) of less than <b>10</b> mm	OK	<ul style="list-style-type: none"> <li>Apply Corrosion-Resistant Compound (CRC) to the vehicles frame and spare tire carrier lift plate (if applicable) according to the separate Technical Instruction.</li> </ul>

### NOTE:

Use protective eyewear and gloves when performing the under vehicle inspection as rusted metal may flake off.

## IV. VEHICLE CONDITION INSPECTION



- Visually inspect both the vehicle interior and exterior. Note any damage found during the visual inspection prior to beginning work.
- As you disassemble the vehicle you may encounter parts that are in need of replacement, which are not covered by this repair procedure. If this is the case, please take the time to inform the customer that these parts can be replaced with no or minimal labor cost.

## V. FRAME REPLACEMENT WORK PROCEDURE



Due to the size and weight of the frame, only **above-ground lifts** are to be utilized when performing the frame replacement on 2001 – 2004 Sequoia Vehicles. If a dealership is not equipped with above-ground lifts, the frame replacement may need to be sublet to a body shop or other dealership business.

### A. SAFETY CHECKLIST & PRECAUTIONS WHEN DRAINING THE FUEL SYSTEM



- Always remember **“SAFETY FIRST”**.
- Be extremely careful when handling fuel to prevent fires from occurring.
- Before beginning work on the fuel system, perform the following safety check list.
- Before removing any fuel system part, drain all fuel to prevent spilling.

#### 1. AIR VENTILATION

- Perform work in a well ventilated area.
- DO NOT** work underground or in an area where fuel vapors may fill the room due to poor ventilation.
- Quickly clean up any spilled fuel with a dry cloth and dissipate the fuel vapors.
- Dry all cloths that have come in contact with fuel in a well ventilated area and dispose of them properly (according to applicable local regulations).

#### 2. FIRES AND IGNITION SOURCES ARE STRICTLY PROHIBITED

- Fires and ignition sources are prohibited while working on the fuel system.
- Clearly display the sign found on the next page stating **“WORKING WITH GASOLINE, NO FIRES OR IGNITION SOURCES”**.
- Smoking is prohibited near the work area.
- DO NOT** work in areas where there are welders, grinders, drills, electric motors, heaters, etc.
- DO NOT** use work lamps or any other electrical appliance due to the risk of sparks flying from the power switch or a rise in temperature.
- DO NOT** use metal hammers while working, due to the risk of flying sparks.
- DO NOT** start any engines or perform any of the above in neighboring work bays.

#### 3. FIRE EXTINGUISHER

- Have a fire extinguisher ready and available before beginning work.

#### 4. PREVENT STATIC ELECTRICITY

- To help prevent static electricity, lightly wet the floor with water, but not to the point where it creates a hazardous working condition.
- Place appropriate warning cones or stand signs around the area as a caution.

#### 5. PRECAUTIONS WHEN USING A LIFT

- For bays equipped with auto lifts, cover all access cover joints with duct tape.
- In the event that fuel has leaked inside the auto lift, remove the access cover and clean up any spilled fuel. Dissipate fuel vapors until the smell is gone.

#### 6. PREVENT THE FUEL FROM SPRAYING

- When disconnecting any fuel tubes, pipes, hoses or connectors there may still be some pressure remaining, even after discharging the system. To prevent the fuel from spraying, cover the tubes, pipes or connectors with a shop rag before disconnecting.
- Remember to always wear protective goggles especially when disconnecting fuel tubes, pipes, hoses or connectors.

#### 7. PREVENT THE FUEL FROM CONTACTING OTHER PARTS

- Do not allow the fuel to come in contact with any parts made of rubber or leather.

#### 8. ASSIGN A SAFETY SUPERVISOR

- Assign a safety supervisor to be in charge of all safety precautions and fire hazards around the work area.

■ Copy And Display When Working

**WORKING WITH  
GASOLINE**

**NO FIRES  
NO IGNITION  
SOURCES**

Supervisor

■ Copiar y exhibir al trabajar

**TRABAJANDO CON  
GASOLINA  
NINGÚN INCENDIOS  
NINGUNA FUENTE  
DE IGNICIÓN**

Supervisor

## B. DEPRESSURIZE THE FUEL SYSTEM PRESSURE AND EVACUATE A/C REFRIGERANT



- The actual vehicle specs, equipment and parts required may differ than what is shown. Please use the correct specs and parts for the model you are working on.
- For additional repair information, please reference to the appropriate repair manual.
- **DO NOT** disconnect any part of the fuel system until you have discharged the fuel pressure.
- Even after discharging the fuel pressure, place a piece of cloth around the lines, pipe, hoses, and connectors as you separate them to reduce the risk of fuel spraying on yourself, in the engine compartment, and onto other parts.
- Before commencing the operation, set the vehicle in the center of a lift, stop it in a position where all the doors can be opened, and center the steering wheel so that the front wheels are in a straight-ahead position.

### 1. CHECK FOR DTCs TO ENSURE VEHICLE ORIGINAL OPERATING CONDITION

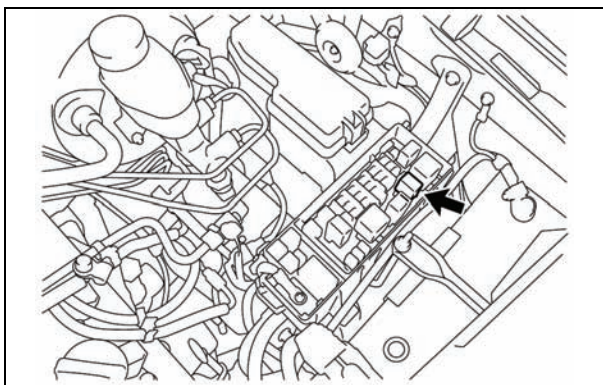

### 2. REMOVE THE FUEL PUMP RELAY

- a) Remove the junction block cover.
- b) Remove the fuel pump relay.

### 3. DISCHARGE THE FUEL SYSTEM PRESSURE

- a) Start the engine.
- b) After the engine has stopped, turn the ignition switch OFF.
- c) Crank the engine again to check that it does not start.

**NOTE:** Make sure to follow the procedure listed above, this prevents a large amount of gasoline from leaking out of the high pressure fuel line when it is disconnected.

### 4. EVACUATE THE A/C REFRIGERANT

### C. PREPERATION FOR REMOVAL OF THE BODY ASSY

1. RECORD THE RADIO STATION PRESETS
2. DISCONNECT THE NEGATIVE (-) BATTERY TERMINAL CABLE

Note: if the vehicle is equipped with power seats, you will need to access the front passenger seat bolts prior to disconnecting the battery in order to remove the seat to access the chassis wire.



- Wait at least 90 seconds after disconnecting the negative (-) battery terminal from the battery to prevent the SRS System from deploying (i.e. airbag, seat belt pretensioner, etc.).

3. REMOVE THE FOLLOWING INTERIOR PARTS TO ACCESS WIREHARNESS CONNECTORS & CAB MOUNTING BOLTS

- Front Door Scuff Plate LH/RH
- Cowl Side Trim Board LH/RH
- Passenger Front Seat
- Glove Compartment Door
- Lower No.2 Instrument Finish Panel
- No.4 Heater To Register Duct



- The actual vehicle specs, equipment and parts required may differ than what is shown. Please use the correct specs and parts for the model you are working on.
- For additional repair information, please reference to the appropriate repair manual.

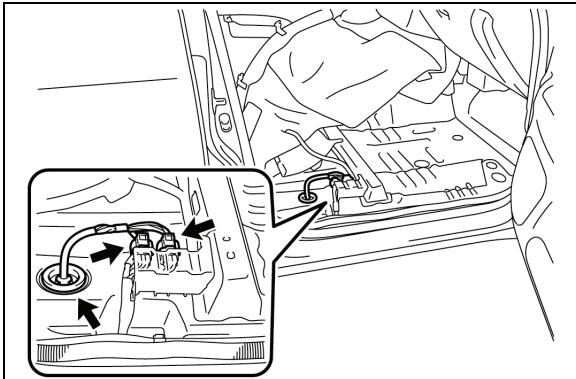

4. DISCONNECT THE FRAME WIRE CONNECTORS

- a) Fold back the floor carpet and disconnect the 2 connectors.
- b) Disconnect the frame wire harness grommet.
- c) Pull out the frame wire harness from the vehicle cab.

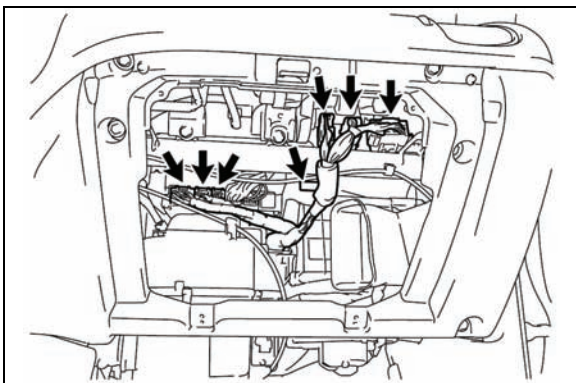

5. DISCONNECT THE ENGINE WIRE HARNESS

- a) Disconnect the 6 connectors and clamp.

**NOTE:** The number of connectors will differ depending on the vehicle specs.

## 6. REMOVE THE FOLLOWING PARTS FROM THE CENTER CONSOLE AREA (4WD Only)

- Transfer Shift Lever Knob
- Shifting Hole Cover
- Upper Console Panel
- No.1 Shift and Select Lever Boot
- Transfer High and Low Shift Lever

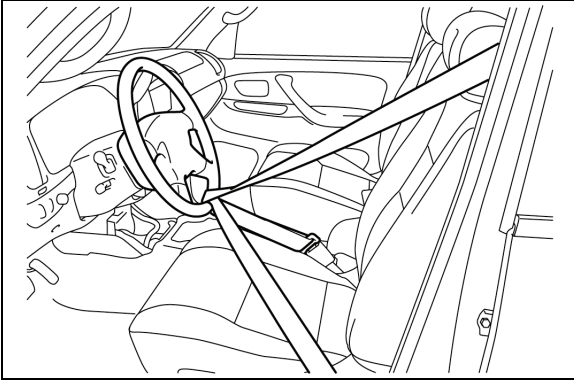

## 7. SECURE THE STEERING WHEEL

- a) Make sure the front wheels are in a straight-ahead position and the steering wheel is centered.
- b) Using the seat belt, hold the steering wheel in position as shown in the illustration, in order to prevent damage to the spiral cable.

## 8. FOLD UP THE 2<sup>nd</sup> ROW SEATS AND REMOVE REAR PASSENGER DOOR SCUFF PLATES

## 9. REMOVE THE FOLLOWING INTERIOR COMPONENTS TO ACCESS CAB MOUNTING BOLTS

- 2<sup>nd</sup> Row Seat Outer Belt Floor Anchor
- 3<sup>rd</sup> Row Seats (*If Equipped*)
- 3<sup>rd</sup> Row Seats Outer Belt Floor Anchors (*If Equipped*)
- Rear Floor Mat Support Plate
- Rear Quarter Trim Panel LH/RH



- Place jack stands under the front and rear portions of the frame to support the frame.
- DO NOT work directly underneath vehicle when preparing the vehicle for cab body assy removal, unless noted.
- The actual vehicle specs, equipment and parts required may differ than what is shown. Please use the correct specs and parts for the model you are working on.
- For additional repair information, please reference to the appropriate repair manual for the vehicle you are working on.

## 10. LIFT VEHICLE ON LIFT

## 11. REMOVE THE FOLLOWING PARTS UNDER VEHICLE COMPONENTS

- No.1 Engine Under Cover
- Side Step Assy LH/RH (if applicable)

## 12. DRAIN THE FOLLOWING FLUIDS

- Engine Coolant (including the engine block)
- Brake Fluid
- Front Differential Oil (4WD ONLY)

**Note:** DO NOT remove the radiator cap while the radiator and engine are hot, as doing so may cause the coolant to spray out causing potential injuries.

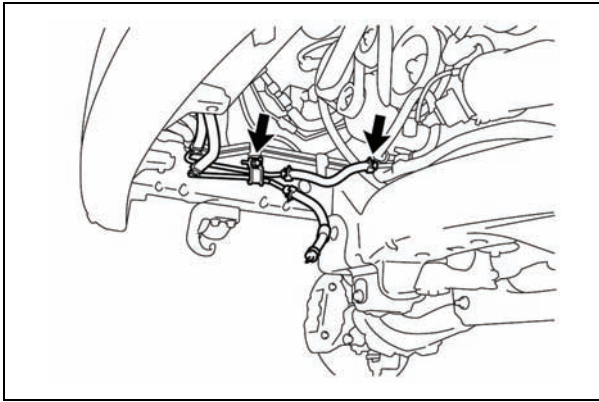

### 13. DISCONNECT THE AUTOMATIC TRANSMISSION NO.2 OIL COOLER OUTLET TUBE

- a) Disconnect the hose.
- b) Remove the bolt and disconnect the No.2 oil cooler outlet tube.

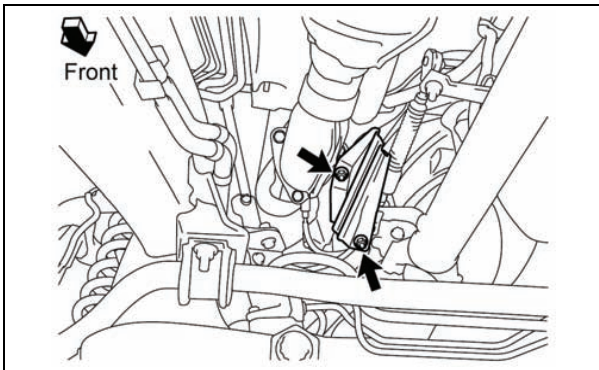

### 14. DISCONNECT THE TRANSMISSION CONTROL CABLE

- a) Remove the 2 nuts and transmission control cable insulator

**NOTE: Use precaution when performing this step, as you will need to work underneath the vehicle.**

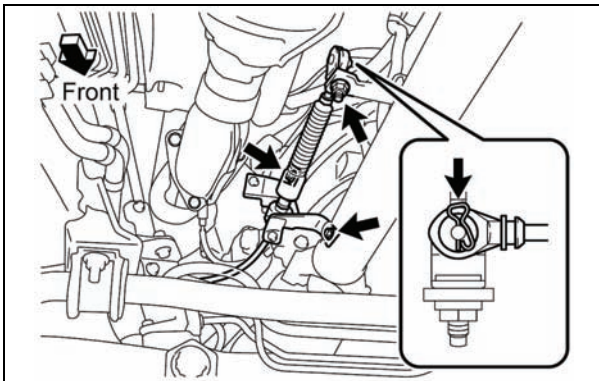

- b) Remove the pin and washer.
- c) Remove the 2 bolts and disconnect the transmission control cable.

**NOTE: If the pin is difficult to remove, remove the nut and then the cable.**

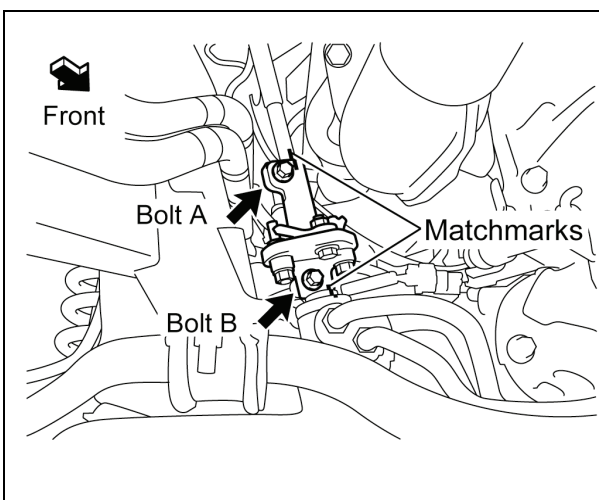

### 15. REMOVE THE NO. 2 STEERING INTERMEDIATE SHAFT

**NOTE:**

**Use precaution when performing this step, as you will need to work underneath the vehicle.**

- a) Place match marks on the steering sliding yoke and No.2 steering intermediate shaft.
- b) Remove the bolt (A).
- c) Place match marks on the No.2 steering intermediate shaft and control valve shaft.
- d) Remove bolt (B).
- e) Slide the No.2 steering intermediate shaft and remove it.

**NOTE: If the No. 2 intermediate shaft assy. is stuck, tap it from below with a brass hammer to disconnect it.**



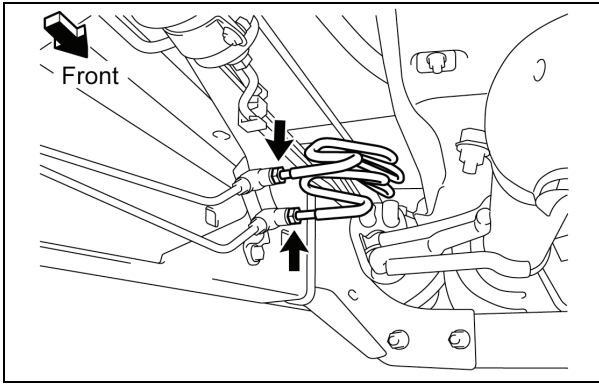

## 16. DISCONNECT THE REAR BRAKE TUBES

- a) Using a flare nut wrench, disconnect the 2 rear brake tubes.

**NOTE: Use precaution when performing this step, as you will need to work underneath the vehicle.**

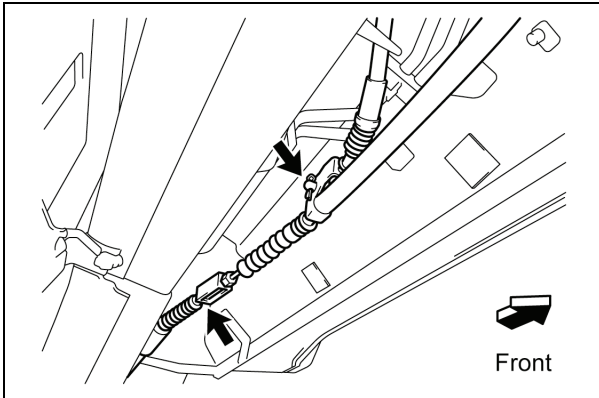

## 17. DISCONNECT THE PARKING BRAKE CABLES

- a) Disconnect the No.1 parking brake cable from the No.3 parking brake cable.
- b) Remove the clip and pin and disconnect the No.2 parking brake cable.

**NOTE: Use precaution when performing this step, as you will need to work underneath the vehicle.**

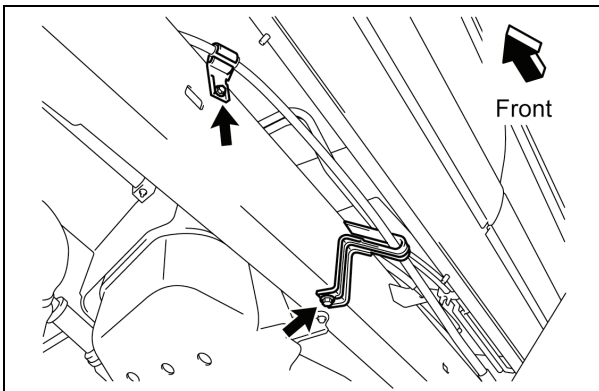

- c) Remove the bolt and cable support bracket from LH side frame rail.
- d) Remove the bolt and disconnect the No.1 parking brake cable from LH side frame rail.

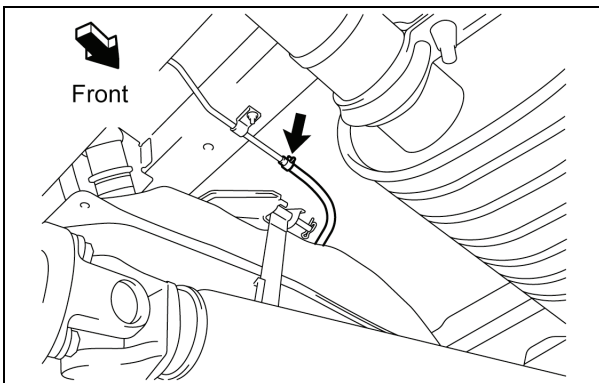

## 18. DISCONNECT THE FUEL TANK VENT HOSE

**NOTE: Use precaution when performing this step, as you will need to work underneath the vehicle.**

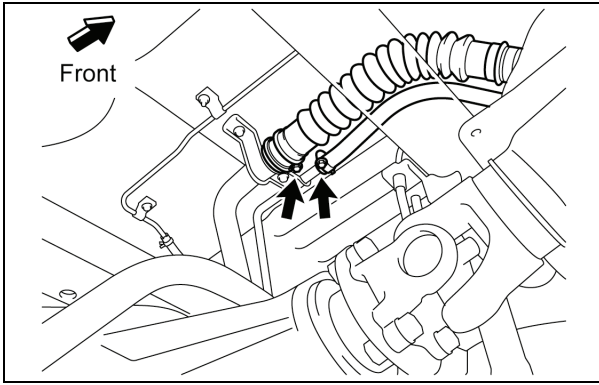

**19. DISCONNECT THE FUEL TANK TO FILLER PIPE HOSE AND FUEL TANK BREATHER HOSE**

**NOTE:** Use precaution when performing this step, as you will need to work underneath the vehicle.

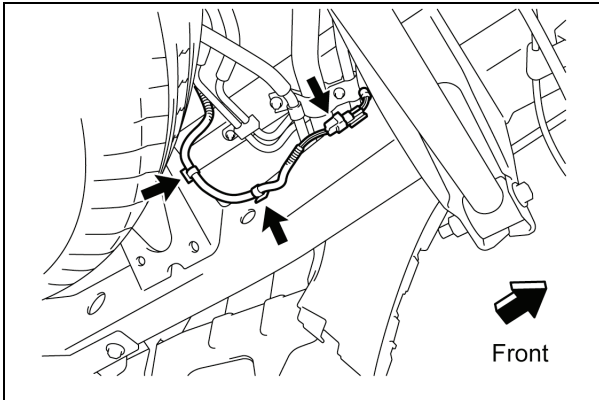

**20. DISCONNECT THE FRAME WIRE**

**NOTE:** Use precaution when performing this step, as you will need to work underneath the vehicle.

a) Disconnect the connector for charcoal canister and clamp(s).

b) Disconnect the connector(s) and clamp(s) for the receiver hitch.

*(Receiver Hitch Equipped Vehicle Only)*

**NOTE:** The number of fastening connectors and clamps for the frame wire will differ depending on the vehicle options. Please verify the current vehicle options and continue.

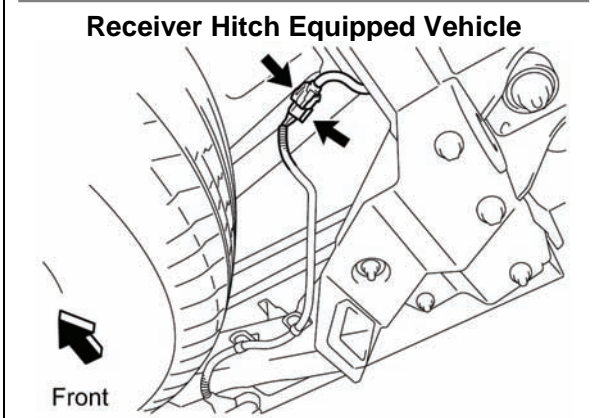

**21. REMOVE THE FOLLOWING FRONT END COMPONENTS**

- Front Fender Mudguard LH/RH
- Front Bumper Assy
- Front Bumper Energy Absorber

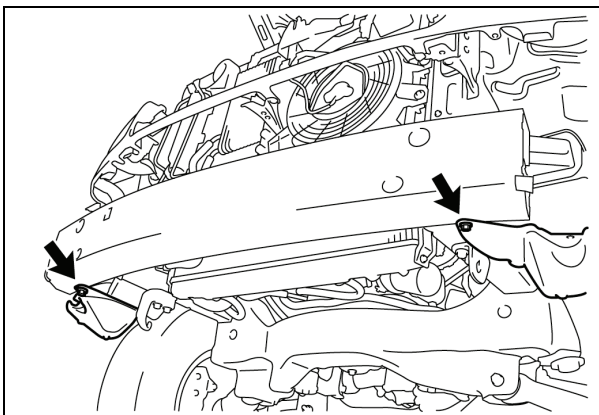

**22. DISCONNECT THE FRONT FENDER LINERS**

a) Remove the 2 screws and disconnect the front fender liners from the front bumper reinforcement.

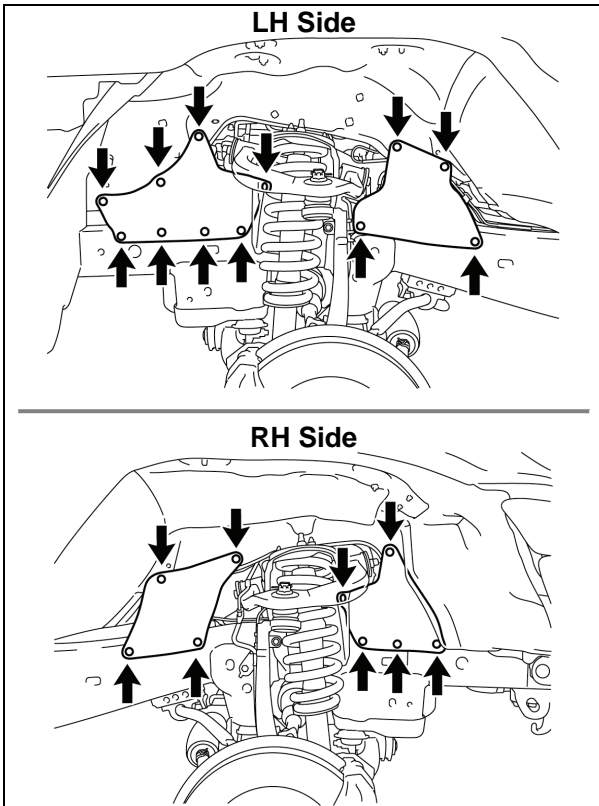

### 23. REMOVE THE FRONT FENDER APRON SEALS

- a) Remove the 21 clips and 4 front fender apron seals.

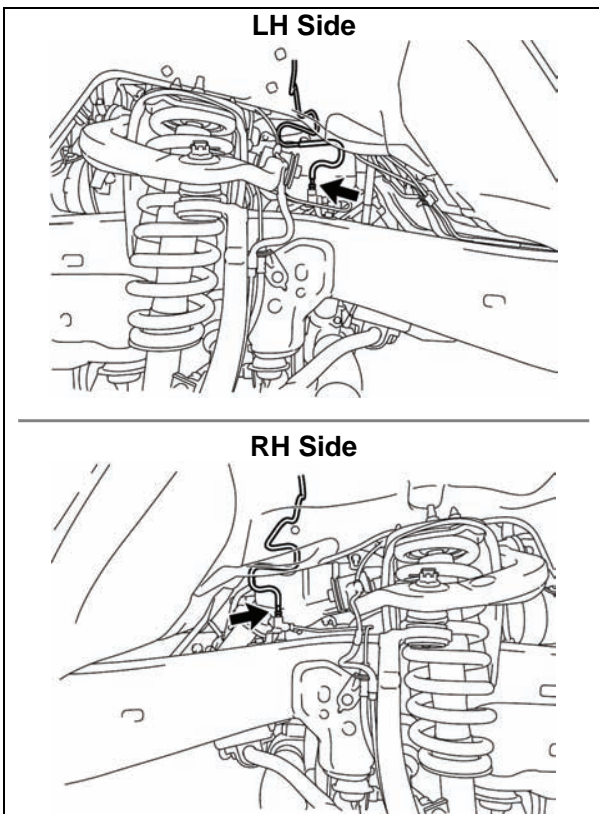

### 24. DISCONNECT THE FRONT BRAKE TUBES

- a) Disconnect the front brake tube.

**Note: Seal off the front brake lines to ensure no rust and debris enters the brake system.**

- b) Repeat the procedure on the opposite side.

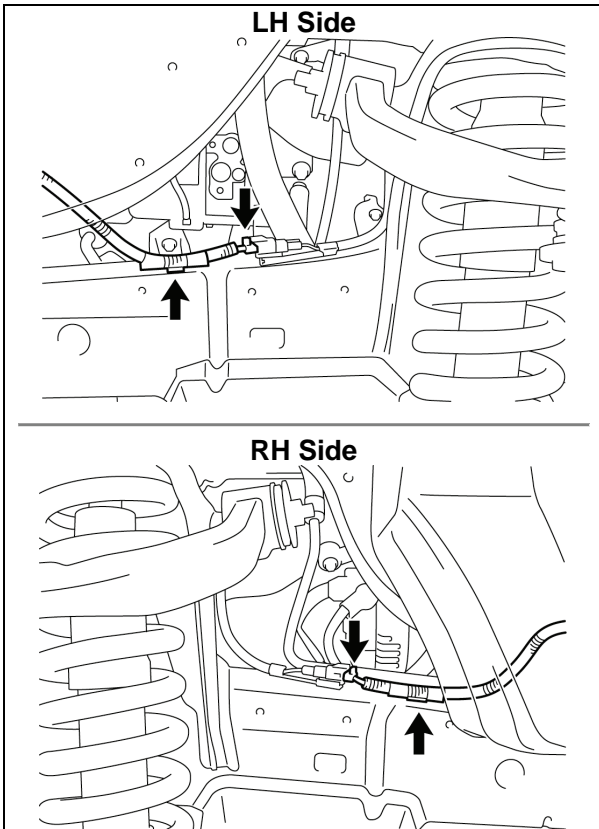

## 25. DISCONNECT THE FRONT SPEED SENSOR CONNECTORS

- a) Disconnect the clamp and front speed sensor connector.
- b) Repeat the procedure on the opposite side.

## 26. REMOVE THE FOLLOWING PARTS

- Rear Quarter Panel Mudguard LH/RH
- Rear Bumper Assy.

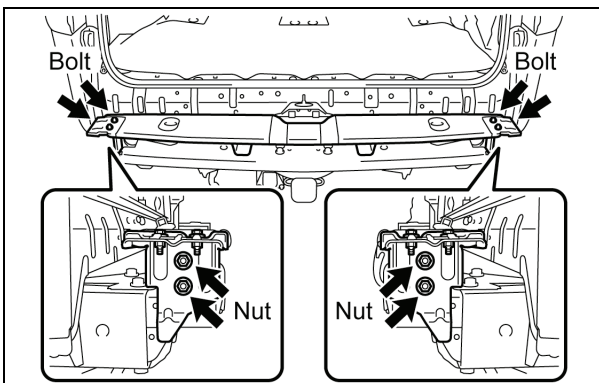

## 27. REMOVE THE REAR BUMPER EXTENSION MOUNTING BRACKET W/ BACK STEP REINFORCEMENT

- a) Loosen the 4 bolts.
- b) Remove the 4 nuts and the rear bumper extension mounting bracket w/ back step reinforcement.

## 28. REMOVE/DISCONNECT THE FOLLOWING PARTS FROM ENGINE COMPARTMENT AREA

- Throttle Body Cover
- Air Cleaner
- Disconnect accelerator control cable (**only on vehicles produced on or before August 2002**)
- Radiator Inlet Hose (disconnect from engine)
- Radiator Outlet Hose (disconnect from engine)
- Disconnect Heater Coolant Hose
- Fan Shroud
- External Trans Cooler (**If Equipped**)
- Radiator Assy

**NOTE:** After disconnecting the automatic transmission oil cooler hoses, plug them and cap the fittings to prevent the ATF from spilling out.

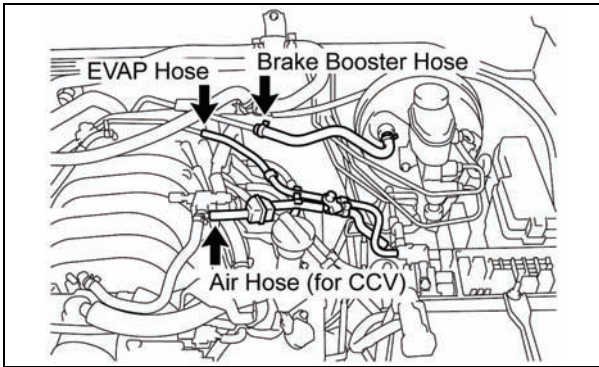

**29. DISCONNECT THE FOLLOWING ENGINE COMPARTMENT HOSES**

- a) Disconnect the brake booster hose.
- b) Disconnect the EVAP hose.
- c) Disconnect the air hose (for CCV).

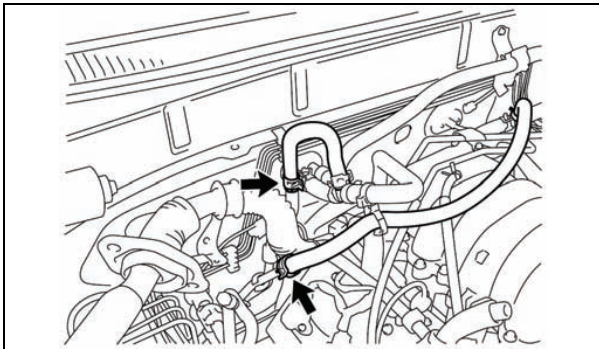

**30. DISCONNECT THE REAR HEATER WATER HOSES (IF EQUIPPED)**

- a) Disconnect the 2 rear heater water hoses from the water pipe.

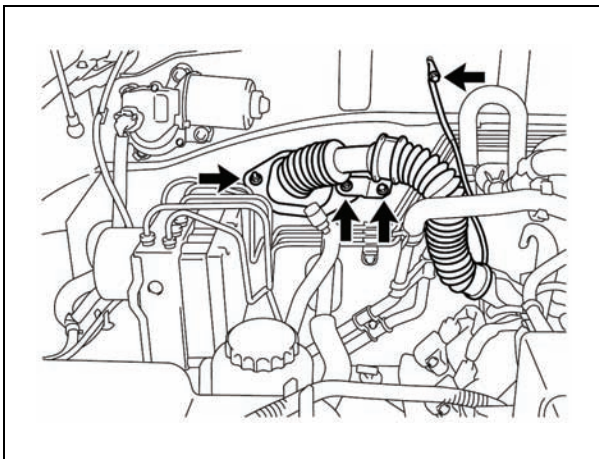

**31. DISCONNECT THE ENGINE WIRE HARNESS**

- a) Remove the bolt and disconnect the ground wire from cowl panel.
- b) Remove the bolt and the 2 nuts holding the engine wire harness connector from the cowl panel.
- c) Gently pull the engine wire harness out from body assembly.

**Note: Ensure all connectors have been previously disconnected from the glove compartment to ensure you do not damage the wire harness**

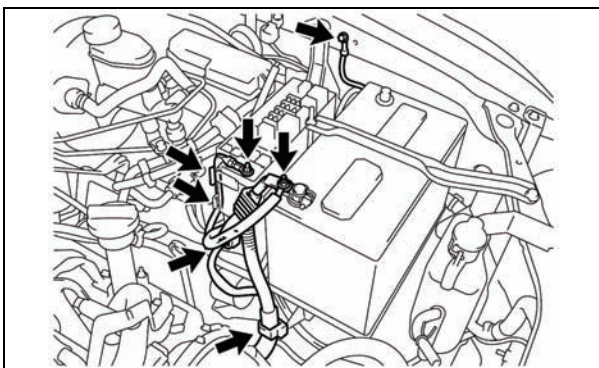

**32. DISCONNECT THE NO.2 ENGINE WIRE HARNESS**

- a) Disconnect the connector and clamp from inner LH front fender.
- b) Remove the bolt and disconnect the ground wire.
- c) Remove the nut and disconnect the positive (+) battery cable.
- d) Remove the nut and 2 clamps and disconnect the No.2 engine wire harness from the junction block.

**33. DISCONNECT THE A/C DISCHARGE HOSE AND SUCTION HOSE**

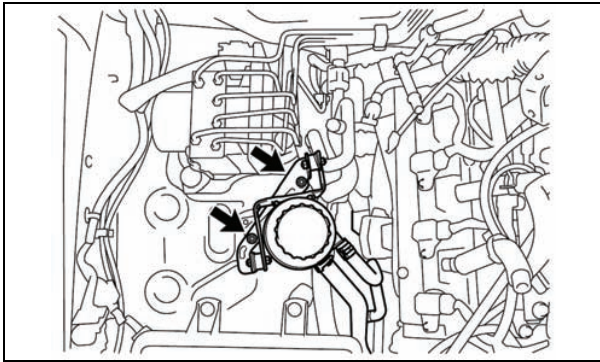

### 34. DISCONNECT THE POWER STEERING PUMP OIL RESERVOIR

- a) Remove the 2 nuts and place the power steering reservoir on the engine assembly.

## D. REMOVAL OF THE BODY ASSY

### 35. REMOVE THE CAB BODY ASSY USING AN ABOVE GROUND LIFT

**Note:** Before rolling chassis out, mark the location of the tires on the floor, this will help align the chassis when the cab is reinstalled.

- a) Remove the 8 nuts and 8 washers.
- b) Set the lift arms under the cab body assy. so they **DO NOT** interfere with the frame or cab mounts.
- c) Check that all wire harnesses, hoses, cables and the steering shaft are disconnected.
- d) Lift the cab assy. up slowly, making sure it does not interfere with anything while being raised.
- e) Raise the cab assy high enough so that the top of the engine clears the lowest point of the cab assy.
- f) Pull the frame assy out from under the cab assembly.
- g) Lower the cab assy all the way down and leave it on the lift.

#### NOTE:

- Center the cab assy weight on the lift arms so that it does not slant/tilt to one side.
- Raise the cab assy slightly off the frame and verify that it is held securely by the lift arms.
- **DO NOT** work directly underneath the vehicle when pulling the frame assy. out from under it.
- **DO NOT** remove the cab mount bolts, as they will be used as guides during the cab assy. reinstallation process.

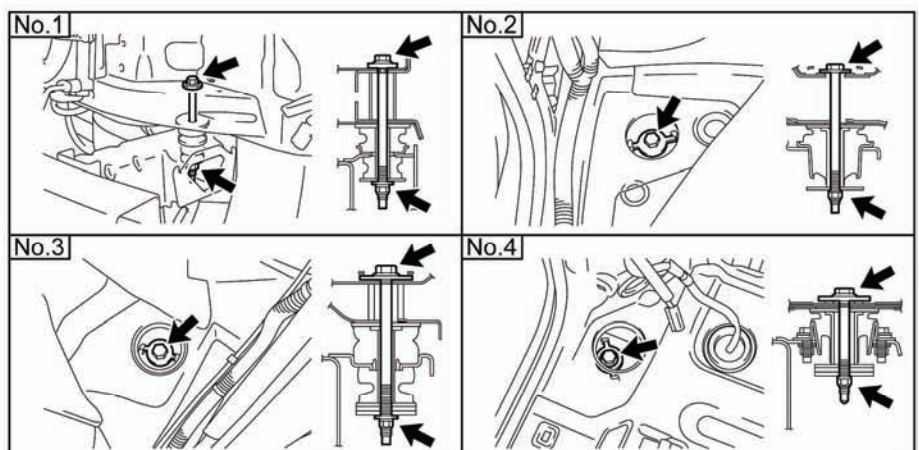
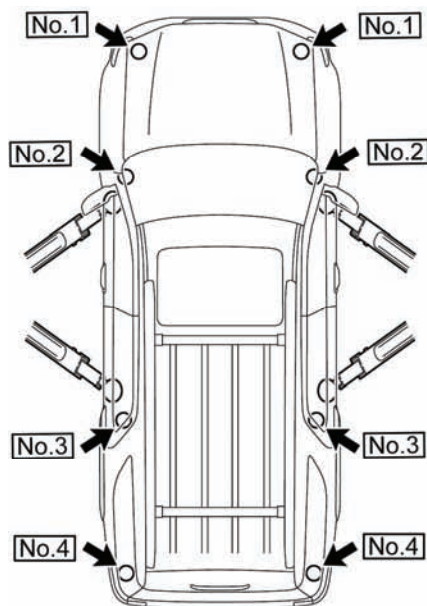

## E. DISASSEMBLE THE FRAME

### 1. PLACE THE FRAME ON A 2<sup>nd</sup> LIFT

a) Place the frame on the 2<sup>nd</sup> lift, and secure it with a ratcheting tie down strap. This will prevent the frame from tilting or falling off as parts are removed.

- **Ratcheting Tie Down: Qty: 1**
  - **Dimensions: 2 in X 27 ft**
  - **Minimum Work Load Capacity: 3,000 lbs**

### 2. REMOVE THE FOLLOWING PARTS

- Spare Tire Carrier
- Receiver Hitch Bracket Assy (*If Equipped*)
- Front Propeller Shaft (*4WD Only*)
- Rear Propeller Shaft
  - Insert the SST into the transmission after the rear propeller shaft is removed to prevent oil leakage.  
**(2WD Only)**
  - **SST: 09325-40010**
- No.1 Fuel Tank Protector
- Fuel Tank Straps
- Fuel Tank

#### NOTE:

**Make sure to place matchmarks on the front (if equipped) and rear propeller shafts before removal.**

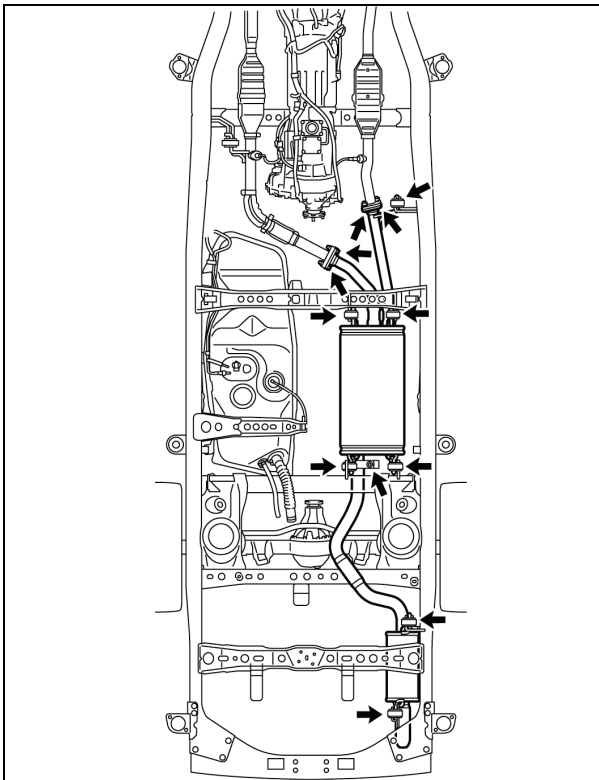

### 3. REMOVE THE EXHAUST SYSTEM

- a) Remove the clamp, 2 rear tail pipe brackets and rear tail pipe.
- b) Remove the 4 bolts, 2 exhaust pipe retainers, 4 exhaust pipe supports and center exhaust pipe.
- c) Remove the 3 exhaust pipe gaskets.

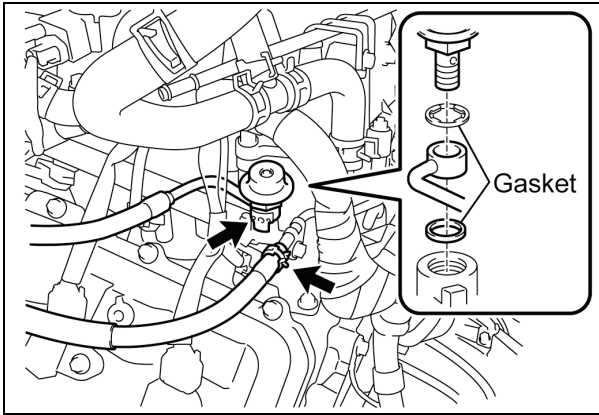

#### 4. DISCONNECT THE FUEL PIPE AND HOSE

- a) Remove the pulsation damper and disconnect the No.1 fuel pipe.
- b) Remove the 2 gaskets.
- c) Disconnect the No.1 fuel hose.

#### NOTE:

- Put a shop towel under the delivery pipe.
- Slowly loosen the pulsation damper.

#### 5. REMOVE THE DRIVE BELT

#### 6. REMOVE AND SET A SIDE THE POWER STEERING PUMP ASSY

- a) Remove the 2 bolts and nut and power steering vane pump assy.

#### NOTE:

- DO NOT disconnect the power steering pump hoses or lines.
- Make sure to keep the power steering pump reservoir in an upright position to prevent the fluid from leaking out.

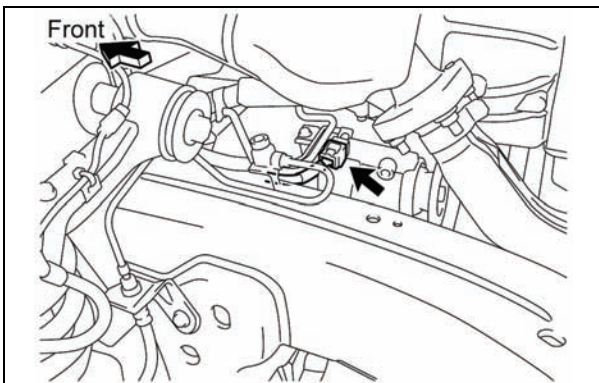

#### 7. DISCONNECT THE A.D.D. ACTUATOR CONNECTOR (4WD ONLY)

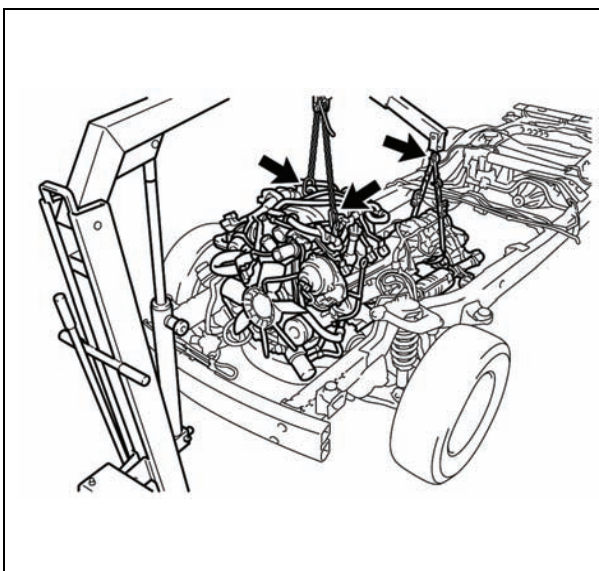

#### 8. REMOVE THE ENGINE AND TRANSMISSION ASSY.

- a) Disconnect and remove the necessary items/parts to prepare the engine and transmission assy for removal.
- b) Remove the engine and transmission assy.

#### NOTE:

- When removing the engine and transmission assy, ALWAYS use 2 engine hoists or mini cranes to lift it.
- DO NOT use 1 engine hoist or mini crane to lift the engine and transmission assy, as the unbalanced weight may lead to an accident or injury.
- ONLY use engine hoists or mini cranes that can properly support the weight of the engine and transmission assy.
- Carefully adjust the 2 engine hoists or mini cranes used so that the engine and transmission assy is properly balanced.

#### 9. REMOVE THE 4 WHEELS



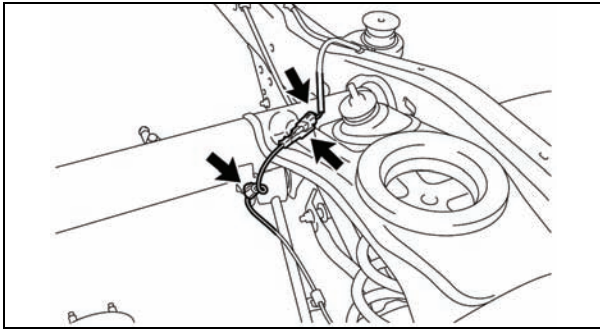

#### 10. DISCONNECT THE REAR SPEED SENSOR CONNECTOR

- a) Remove the 2 clamps and disconnect the rear speed sensor connector.
- b) Repeat the procedure on the opposite side.

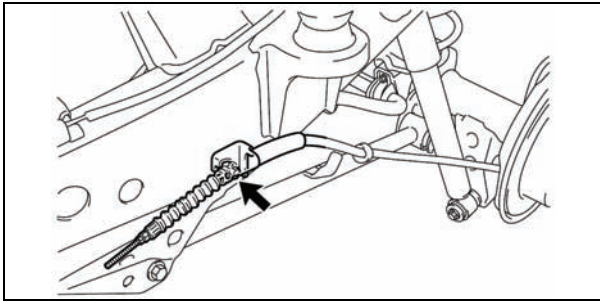

#### 11. DISCONNECT THE NO.3 PARKING BRAKE CABLE

- a) Remove the bolt and disconnect the No.3 parking brake cable.

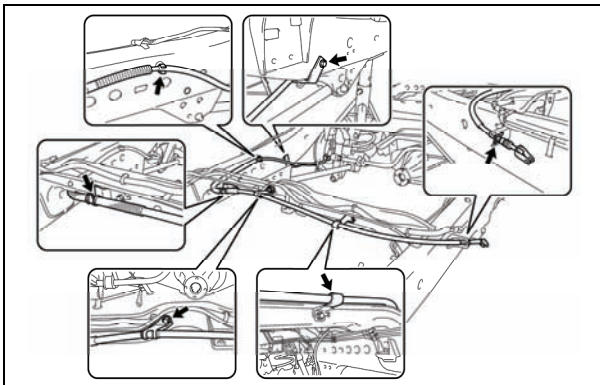

#### 12. REMOVE THE NO.2 PARKING BRAKE CABLE

- a) Remove the clip.
- b) Remove the 2 bolts.
- c) Disconnect the No.2 parking brake cable from the 3 clamps.

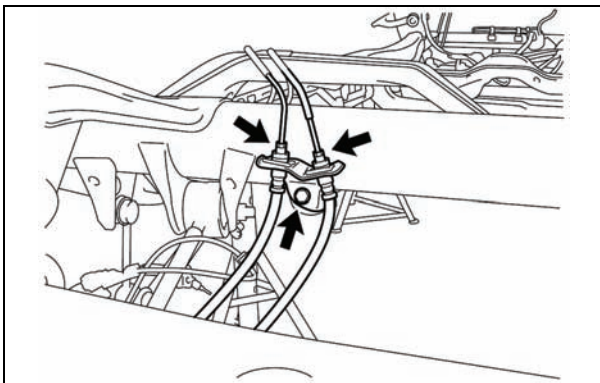

#### 13. DISCONNECT THE REAR BRAKE FLEXIBLE HOSES

- a) Using a flare nut wrench, disconnect the 2 rear brake tubes.
- b) Remove the bolt and disconnect the No.5 flexible hose bracket.

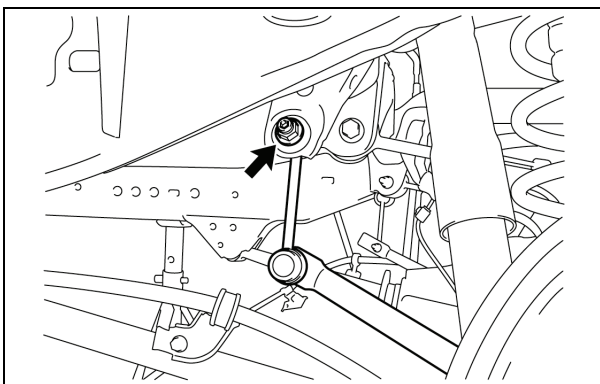

#### 14. DISCONNECT THE REAR STABILIZER BAR

- a) Remove the 2 nuts and disconnect the 2 rear stabilizer links from the frame.
- b) Remove the 4 bolts, 2 brackets and rear stabilizer bar.

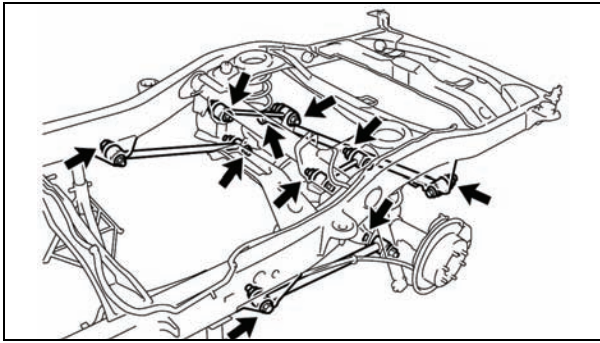

### 15. LOOSEN THE REAR SUSPENSION ARMS

- a) Loosen the bolts and nuts of the rear suspension arms, at the rear axle housing.
- b) Loosen the bolts and nuts of the rear suspension arms at the frame.

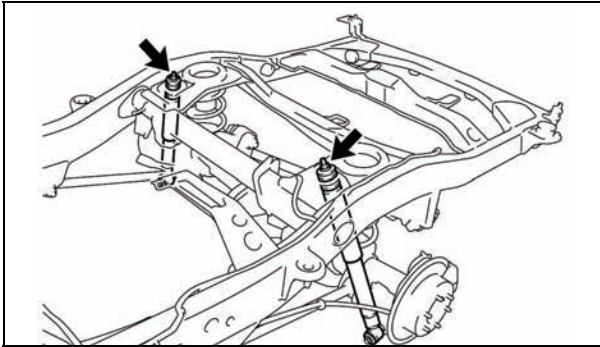

### 16. DISCONNECT THE REAR SHOCK ABSORBERS

- a) Using a floor jack raise the rear axle housing.
- b) Remove the 2 nuts and 2 retainers and disconnect the rear shock absorbers.

### 17. REMOVE THE REAR AXLE HOUSING W/ LINK ASSY

- a) Position the floor jack underneath the center section of the rear axle to support during the disassembly process.
- b) Remove the 2 bolts, washer, nut and the rear lateral control rod (Illustration A).
- c) Remove the 2 bolts, 2 washers and 2 nuts and disconnect the No.1 rear suspension arms from the frame (Illustration B).
- d) Slowly lower the jack, and remove the rear coil springs and hollow springs (Illustration C).
- e) Remove the 2 bolts, 2 washers and 2 nuts and disconnect the lower control arms from the frame (Illustration C).
- f) Roll the rear axle assembly away from frame.

Illustration A

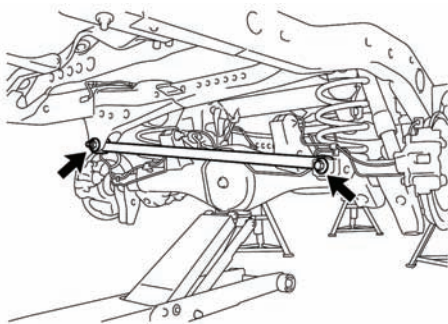

Illustration B

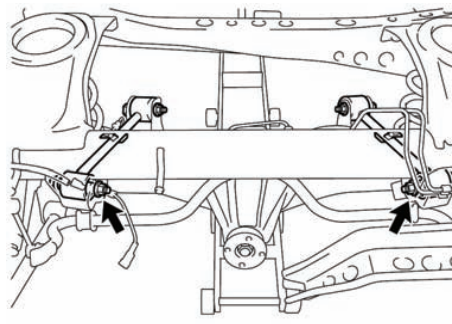
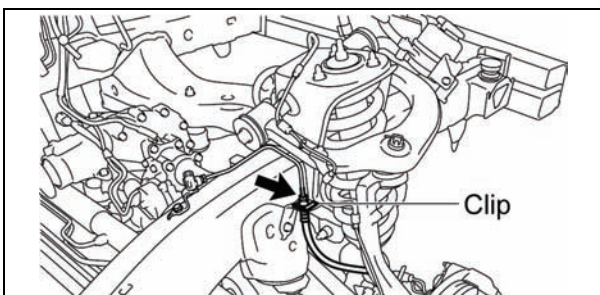
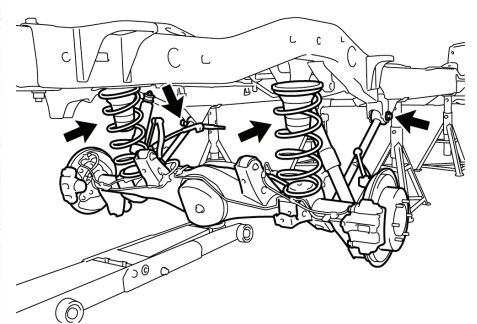
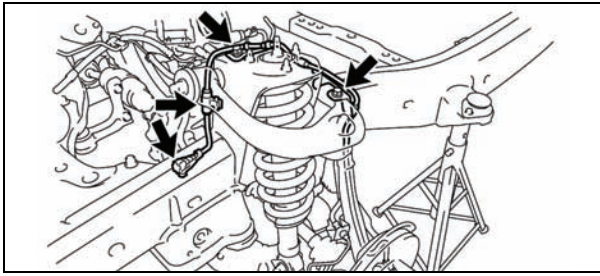

Illustration C



### 18. DISCONNECT THE NO.1 FRONT BRAKE FLEXIBLE HOSES

- a) Disconnect the front brake tube.
- b) Remove the clip and disconnect the No.1 flexible hose.
- c) Plug the hose to ensure not rust or debris enter the brake hose
- d) Repeat the procedure on the opposite side.



### 19. DISCONNECT THE FRONT SPEED SENSOR CONNECTORS

- a) Remove the 2 bolts and 2 clamps and disconnect the front speed sensor connector.
- b) Repeat the procedure on the opposite side.

### 20. REMOVE THE FOLLOWING FRONT END COMPONENTS

- Front Bumper Reinforcement
- Front Stabilizer Bar
- Front Axle Shaft Nuts (**4WD Only**)
- Tie Rod Ends
  - Remove the cotter pins and nuts.
  - Using the SST, disconnect the tie rod ends.
  - **SST: 09610-20012**
- Front Lower Ball Joints
  - Remove the cotter pins and nuts.
  - Using the SST, disconnect the lower ball joint.
  - **SST: 09628-62011**

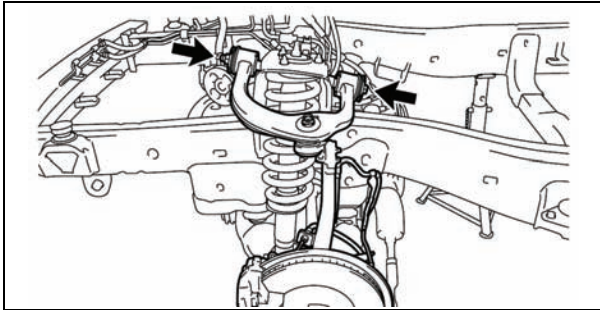

### 21. REMOVE THE FRONT SUSPENSION UPPER ARMS W/ STEERING KNUCKLE AND STRUT ASSY

- a) Remove the bolt, nut, 2 washers and front suspension upper arm w/ steering knuckle.
- b) Repeat the procedure on the opposite side.

**NOTE:**

If the drive shaft is difficult to disconnect, tap it loose with a plastic hammer.

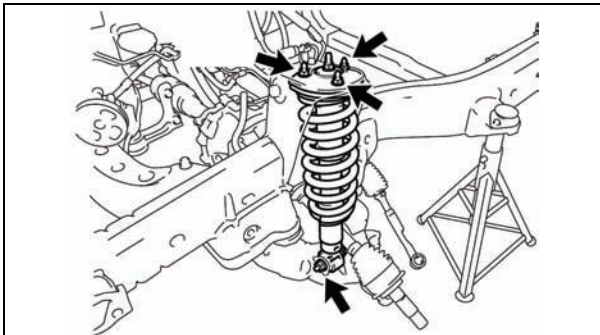

### 22. REMOVE FRONT STRUT ASSY AND LOWER CONTROL ARMS

- a) Remove Front Strut Assy by removing the three nuts and bolt.
- b) Repeat procedure on opposite side.
- c) Remove Front Suspension Lower Control Arm

### 23. REMOVE THE FOLLOWING POWERTRAIN COMPONENTS

- Power Steering Gear Assy w/ Power Steering Vane Pump
- Front Drive Shafts (**4WD Only**)
  - Using the SST, remove the drive shafts.
  - **SST: 09520-01010, 09520-32040**
- Front Differential Carrier (**4WD Only**)

**NOTE:**

- When removing the power steering rack with the pump assy attached, have one person support the power steering rack and the other support the pump assy.
- Keep the power steering pump reservoir in an upright position to prevent fluid from leaking out.
- If the drive shaft is difficult to remove tap it with a plastic hammer.
- Be careful not to damage the dust cover and oil seal.

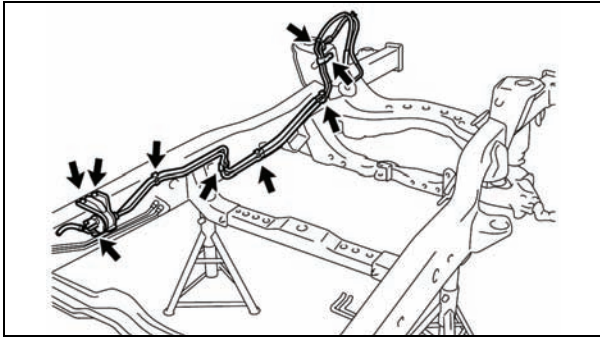

#### 24. REMOVE THE FUEL TUBES

- a) Remove the bolts and clamps and the fuel tubes.

**NOTE:**

- The number of fastening clips and clamps for the fuel tubes will differ depending on the vehicle model. Please verify the current vehicle and continue.

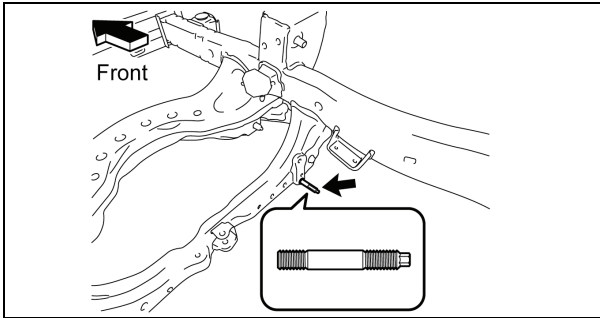

#### 25. REMOVE THE STUD BOLT

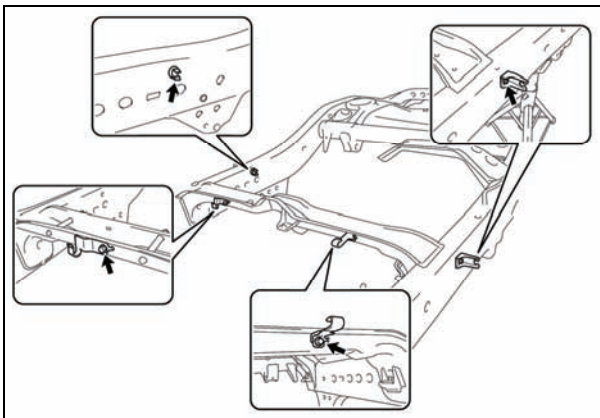

#### 26. REMOVE THE FRONT PARKING BRAKE CABLE RETAINER BRACKET AND CLAMPS

- a) Remove the bolt and the front cable retainer bracket from crossmember.
- b) Remove the 2 bolts and the clamps from crossmember and LH frame rail.
- c) Remove the clamp from RH side frame rail.

#### 27. REMOVE THE REMAINING COMPONENTS

- Front Spring Bumpers
- Rear Spring Bumpers
- Cab Mounting Cushions (Qty: 8)

#### 28. REMOVE THE FRAME FROM THE LIFT

## F. ASSEMBLE THE NEW FRAME

### 1. PLACE THE **NEW** FRAME ON THE LIFT

- a) Place the **NEW** frame on the lift, and secure it with a ratcheting tie down strap. This will prevent the frame from tilting or falling off as parts are installed.

- **Ratcheting Tie Down: Qty: 1**
  - **Dimension: 2 in X 27 ft**
  - **Minimum Work Load Capacity: 3,000 lbs**

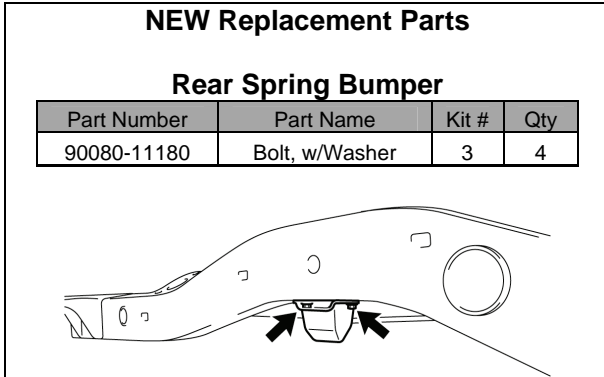

### 2. REINSTALL THE REAR SPRING BUMPER

- a) Reinstall the rear spring bumper with the 2 **NEW** bolts and torque to spec.
- b) Repeat the procedure on the opposite side.

**Torque Spec: 29 N·m (296 kgf·cm, 21 ft·lbf)**

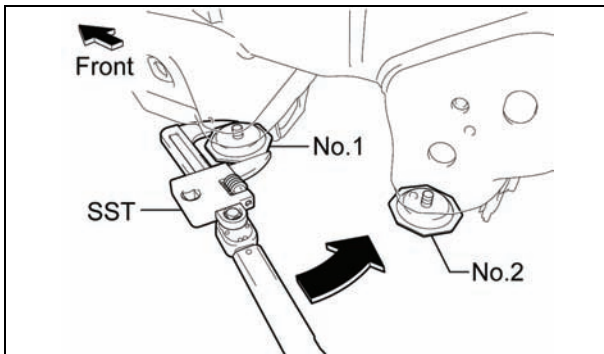

### 3. REINSTALL THE FRONT SPRING BUMPER

- a) Using the SST, reinstall the No.1 and No.2 front spring bumpers to the frame and torque to spec.
- b) Repeat the procedure on the opposite side.

**SST: 09922-10010**

**Torque Spec: 31 N·m (316 kgf·cm, 23 ft·lbf)**

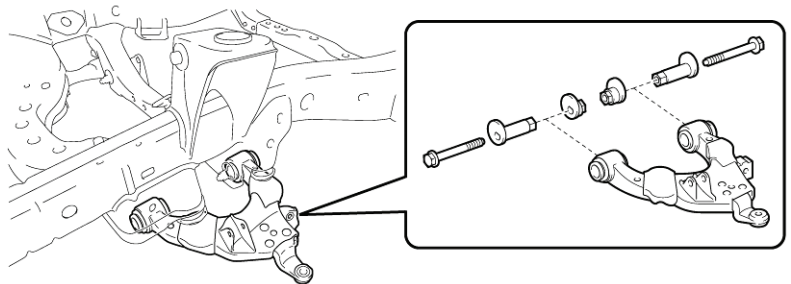
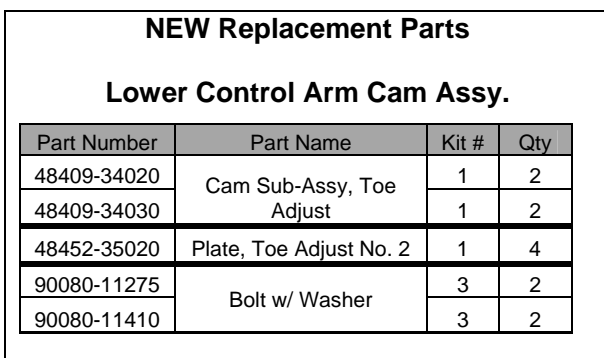

### 4. REINSTALL THE FRONT SUSPENSION LOWER CONTROL ARM

- a) Reinstall the front suspension lower control arm with 2 **NEW** bolts, 2 **NEW** toe adjustment plates, and 2 **NEW** toe adjustment cams, then torque to spec.

**Torque Spec: 130 N·m (1326 kgf·cm, 96 ft·lbf)**

- b) Repeat the procedure on the opposite side.

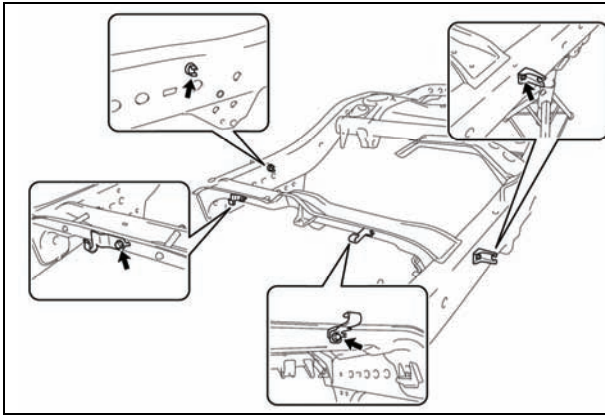

5. **REINSTALL THE PARKING BRAKE CABLE RETAINER BRACKETS AND CLAMPS**
- Reinstall the clamp.
  - Reinstall the clamps with the 2 bolts and torque to spec.
  - Reinstall the front parking brake cable retainer bracket with the bolt and torque to spec.

**Torque Spec: 26 N-m (265 kgf-cm, 19 ft-lbf)**

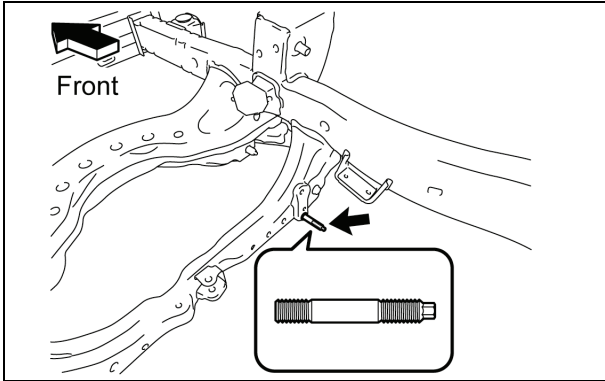

6. **REINSTALL THE STEERING GEAR STUD BOLT**
- Reinstall the stud bolt and torque to spec.

**Torque Spec: 20 N-m (204 kgf-cm, 15 ft-lbf)**

**NEW Replacement Parts**

**Front Bumper Reinforcement**

Part Number	Part Name	Kit #	Qty
90178-10024	Nut, Flange	1	4

7. **REINSTALL THE FRONT BUMPER REINFORCEMENT**
- Reinstall the front bumper reinforcement with the 4 **NEW** nuts and torque to spec.

**Torque Spec: 50 N-m (510 kgf-cm, 37 ft-lbf)**

**NEW Replacement Parts**

**Rear Bumper Reinforcement**

Part Number	Part Name	Kit #	Qty
90119-A0026	Bolt w/Washer	3	4
90119-A0027	Bolt w/ Washer	3	2
94130-01232	Nut, Hexagon	1	6
94622-31200	Washer, Plate	1	6

8. **INSTALL THE REAR BUMPER REINFORCEMENT SET (If applicable)**
- Install the rear bumper reinforcement set with the 6 **NEW** bolts, 6 **NEW** nuts and 6 **NEW** washers, then torque to spec.

**Torque Spec: 95 N-m (970 kgf-cm, 70 ft-lbf)**

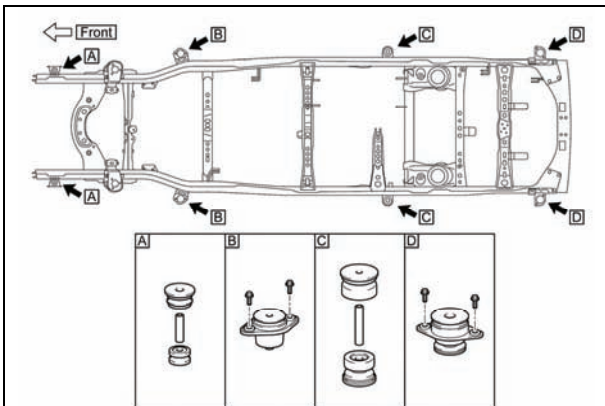

9. **REINSTALL THE CAB MOUNTS**
- Reinstall the 8 cab mounts.

**Torque Spec: 61 N-m (622 kgf-cm, 45 ft-lbf)**

## 10. INSTALL THE **NEW** REAR BRAKE TUBES

- Install the **NEW** rear brake tubes with the 7 **NEW** clamps.
- Install the **NEW** 2 way with the **NEW** bolt and torque to spec.

**Torque Spec: 28 N·m (286 kgf·cm, 21 ft·lbf)**

### NEW Replacement Parts

Part Number	Part Name	Kit #	Qty
47323-0C020	Tube, RR Brake, No.3	N/A*	1
47326-0C020	Tube, RR Brake, No.6	N/A*	1
90904-12068	Way, 2	1	1
90949-01C06	Clamp	1	7
91621-B0816	Bolt w/ Washer	1	1

\*Individual Part (s)

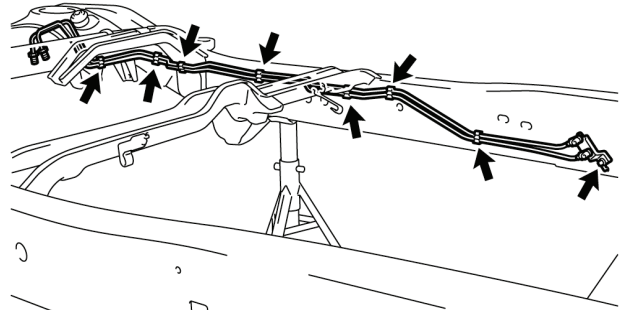

## 11. REINSTALL THE FUEL TUBES

- Reinstall the fuel tubes with the **NEW** bolts and **NEW** clamps, then torque to spec.

### Torque Specs:

**Clamp Bolt - 29 N·m (296 kgf·cm, 21 ft·lbf)**

**Filter Bolt - 20 N·m (204 kgf·cm, 15 ft·lbf)**

**NOTE:**The number of bolts and clamps will differ depending on the vehicle specs.

### NEW Replacement Parts

Part Number	Part Name	Kit #	Qty
77285-34031	Clamp, Fuel Tube, No.1 (TYPE A)	1	5
77285-34060	Clamp, Fuel Tube, No.1 (TYPE B)	1	1
77285-34080	Clamp, Fuel Tube, No.1 (TYPE C)	1	1
77285-34200	Clamp, Fuel Tube, No.1 (TYPE E)	1	1
90080-11180	Bolt, w/ Washer	3	2

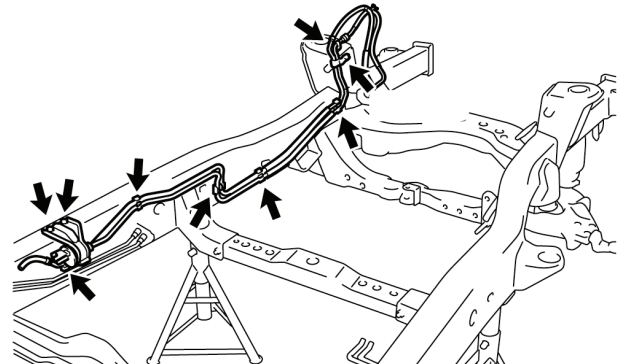

## 12. INSTALL THE **NEW** FRAME WIRE HARNESS

- Reconnect the clamps to install the **NEW** frame wire harness.
- Reconnect the ground wire with the bolt and torque to spec.

**Torque Spec: 29 N·m (296 kgf·cm, 21 ft·lbf)**

**NOTE:** The number of clamps will differ depending on the vehicle specs.

### NEW Replacement Parts

Part Number	Part Name	Kit #	Qty
82164-0C040	Wire, Frame	3	1

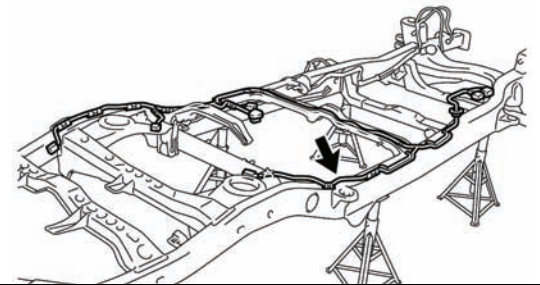

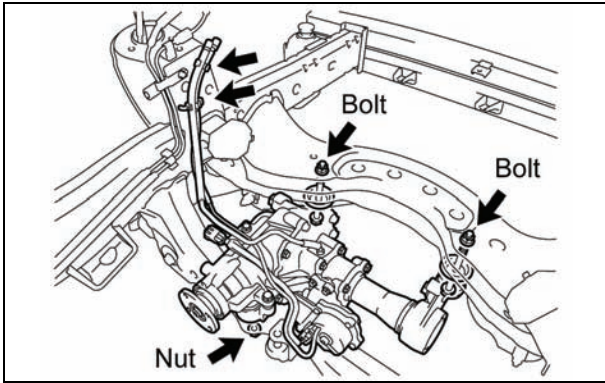

### 13. REINSTALL THE FRONT DIFFERENTIAL CARRIER ASSY (4WD ONLY)

- Reinstall the front differential carrier assy with the 2 bolts, 4 stoppers and 3 nuts, then torque to spec.
- Reinstall the front differential breather tube with the 2 clamps.

#### Torque Spec:

**Bolt - 137 N·m (1397 kgf·cm, 101 ft·lbf)**

**Nut - 87 N·m (887 kgf·cm, 64 ft·lbf)**

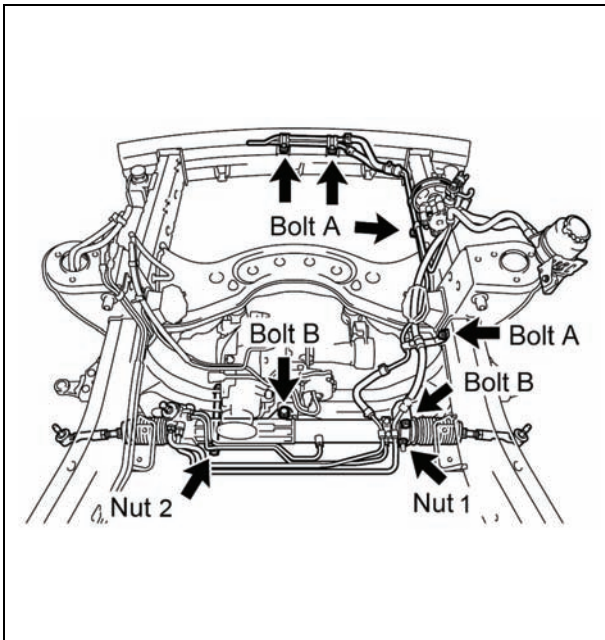

### 14. REINSTALL THE POWER STEERING LINK ASSY W/ POWER STEERING VANE PUMP

- Reinstall the power steering link assy w/ power steering vane pump with the 6 bolts, washer and 2 nuts, then torque to spec.

#### Torque Spec:

**Bolt A - 29 N·m (296 kgf·cm, 21 ft·lbf)**

**Bolt B - 165 N·m (1682 kgf·cm, 122 ft·lbf)**

**Nut 1 - 165 N·m (1682 kgf·cm, 122 ft·lbf)**

**Nut 2 - 130 N·m (1326 kgf·cm, 96 ft·lbf)**

#### NOTE:

- When reinstalling the power steering link with the vane pump attached, have one person support the power steering link and the other support the vane pump.
- Make sure to keep the power steering pump reservoir in an upright position to prevent the fluid from leaking out.

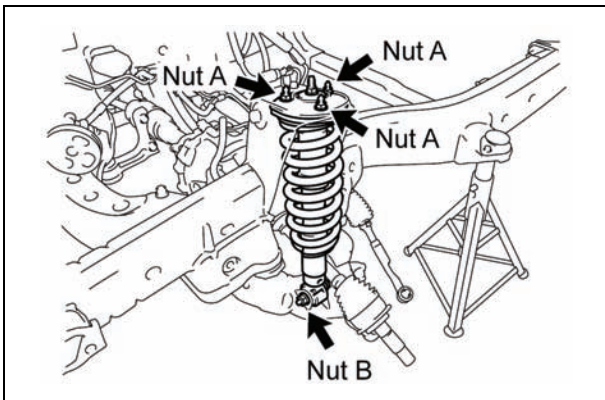

### 15. REINSTALL THE FRONT SHOCK ABSORBER ASSY

- Reinstall the front shock absorber assy with 3 nut (A) and torque to spec.
- Reinstall the front shock absorber assy to the lower control arm with the bolt and nut (B), then torque to spec.

#### Torque Spec:

**Nut A - 64 N·m (653 kgf·cm, 47 ft·lbf)**

**Nut B - 135 N·m (1377 kgf·cm, 100 ft·lbf)**

- Repeat the procedure on the opposite side.

### NEW Replacement Parts

#### Front Drive Shaft

Part Number	Part Name	Kit #	Qty
43425-04020	Ring, Drive Shaft Snap	N/A*	2

\*Individual Part(s)

### 16. REINSTALL THE FRONT DRIVE SHAFTS (4WD ONLY)

- Install a **NEW** snap ring.
- Reinstall the front drive shaft.
- Repeat the procedure on the opposite side.

**NOTE: Be careful not to damage the dust cover and oil seal.**



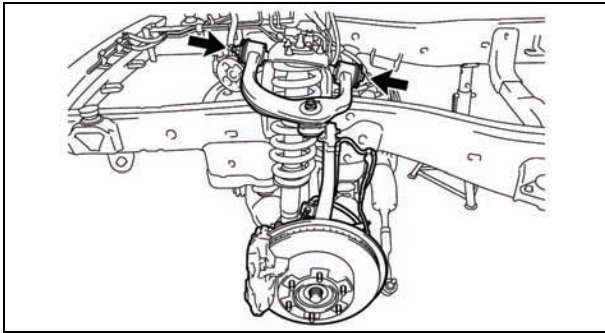

### 17. REINSTALL THE FRONT SUSPENSION UPPER ARM W/ STEERING KNUCKLE

- a) Reinstall the front suspension upper arm w/ steering knuckle with the bolt, nut and 2 washers, then torque to spec.

**Torque Spec: 98 N-m (999 kgf-cm, 72 ft-lbf)**

- b) Repeat the procedure on the opposite side.

#### NEW Replacement Parts

##### Front Lower Ball Joint

Part Number	Part Name	Kit #	Qty
90252-03015	Pin, Cotter	1	2

##### Tie Rod End

Part Number	Part Name	Kit #	Qty
95381-03225	Pin, Cotter	1	2

##### Front Stabilizer Bar

Part Number	Part Name	Kit #	Qty
48824-34030	Bracket, Stabilizer, RH	1	1
48829-34020	Bracket, Stabilizer, LH	1	1
90080-11482	Bolt w/ Washer	3	2
90182-10004	Nut, w/ Washer	1	2

### 18. REINSTALL THE FOLLOWING PARTS

- Front Lower Ball Joints
  - Reinstall the front lower ball joint with the nut and torque to spec.
  - Install the **NEW** cotter pin.
  - **Torque Spec: 140 N-m (1428 kgf-cm, 103 ft-lbf)**
  - Repeat the procedure on the opposite side.
- Tie Rod Ends
  - Reinstall the tie rod end with the nut and torque to spec.
  - Install the **NEW** cotter pin.
  - **Torque Spec: 91 N-m (928 kgf-cm, 67 ft-lbf)**
  - Repeat the procedure on the opposite side.
- Front Axle Shaft Nuts (**4WD Only**)
  - Temporarily install the front axle nut. This nut will be tightened when the vehicle is completed.
  - Repeat the procedure on the opposite side.
- Front Stabilizer Bar
  - Reinstall the stabilizer bar and 2 **NEW** brackets with the 2 **NEW** bolts and 2 **NEW** nuts, then torque to spec.
  - **Torque Spec: 37 N-m (377 kgf-cm, 27 ft-lbf)**
  - Reinstall the stabilizer bar link with the 2 nuts and torque to spec.
  - **Torque Spec: 69 N-m (704 kgf-cm, 51 ft-lbf)**

#### NEW Replacement Parts

##### Front Speed Sensor

Part Number	Part Name	Kit #	Qty
89542-0C010	Sensor, Speed, Front RH	3	1
89543-0C010	Sensor, Speed, Front LH	3	1

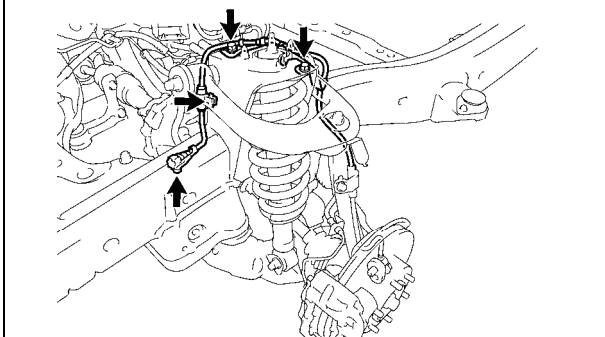

### 19. CONNECT THE NEW FRONT SPEED SENSORS

- a) Install the front speed sensor with the 3 bolts and 2 clamps, then torque to spec.

**Torque Spec: 8.0 N-m (82 kgf-cm, 71 in-lbf)**

- b) Repeat the procedure on the opposite side.

## NEW Replacement Parts

### Front Brake Flex Hose

Part Number	Part Name	Kit #	Qty
47353-35110	Bracket, Flexible Hose No. 3	1	1
47354-35100	Bracket, Flexible Hose No. 4	1	1
90468-08035	Clip	1	2
91621-B0816	Bolt, w/ Washer	1	2

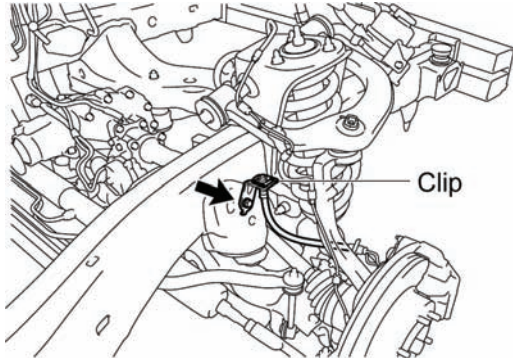

## 20. RECONNECT THE FRONT BRAKE FLEXIBLE HOSES

- Install the **NEW** bracket with the **NEW** bolt and torque to spec.

**Torque Spec: 28 N-m (286 kgf-cm, 21 ft-lbf)**

- Reconnect the flexible hose with the **NEW** clip.
- Repeat the procedure on the opposite side.

## NEW Replacement Parts

### Brake Tubes and 2 Way

Part Number	Part Name	Kit #	Qty
47314-0C011	Tube, FR Brake, No. 4	3	1
47317-0C011	Tube, FR Brake, No. 7	3	1
90904-12066	Way, 2	1	1
90904-12067		1	1
91621-B0816	Bolt, w/ Washer	1	2

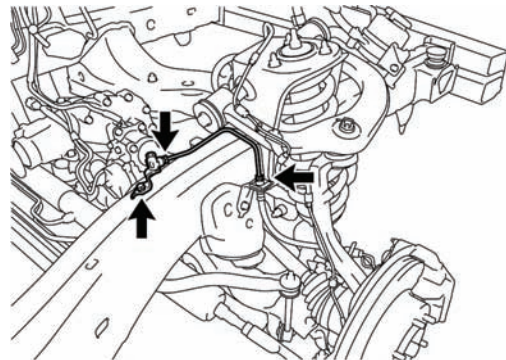

## 21. INSTALL THE NEW FRONT BRAKE TUBES AND 2 WAYS

- Temporarily install the **NEW** front brake tube and **NEW** 2 way.
- Reinstall the front brake tube and 2 way with the **NEW** bolt and torque to spec.

**Torque Spec: 28 N-m (286 kgf-cm, 21 ft-lbf)**

- Reconnect the front brake tube and torque to spec.

**Torque Spec: 16 N-m (163 kgf-cm, 12 ft-lbf)**

- Repeat the procedure on the opposite side.

## 22. REINSTALL THE REAR AXLE HOUSING W/ LINK ASSY

- Place rear axle on floor jack and position under the frame.
- Temporarily reinstall the 2 bolts, 2 nuts and 2 washers on the frame side of the lower control arms to the frame.
- Set the rear coil springs and hollow springs on the rear axle housing.

### NOTE:

- After stabilizing the suspension, torque the bolts and nuts.
- Be sure to raise one side of the rear axle housing at a time.
- Install the rear lateral control rod after positioning the body on it.

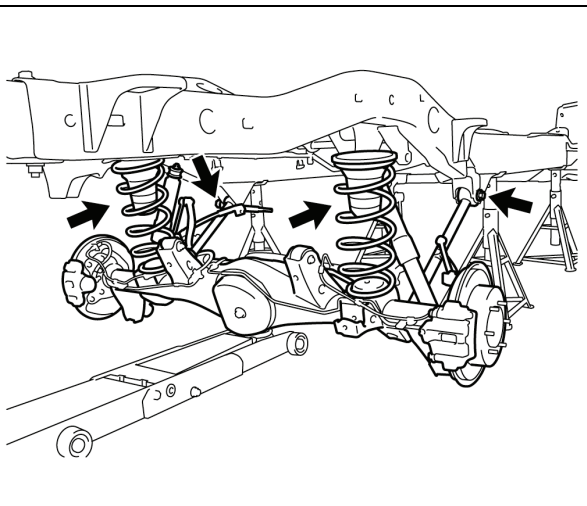

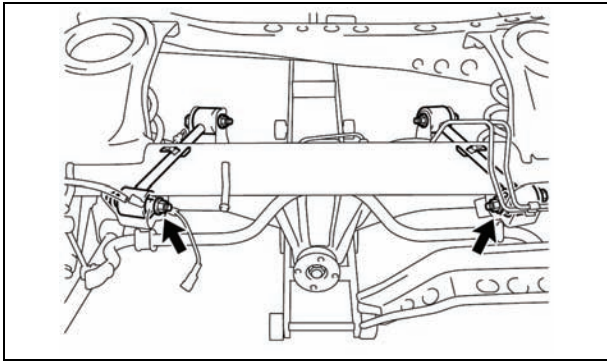

- d) Raise the jack, and temporarily install the 2 bolts, 2 nuts and 2 washers on the frame side of the No.1 rear suspension arm to the frame.

**NOTE:**

- After stabilizing the suspension, torque the bolt and nuts.
- Be sure to raise one side of the rear axle housing at a time.
- Install the rear lateral control rod after positioning the body on it.

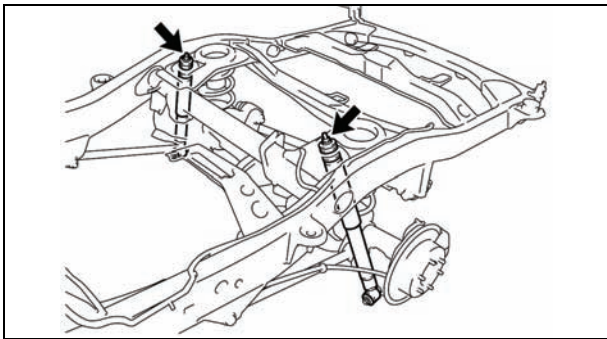

- e) Reconnect the rear shock absorbers with the 2 nuts and 2 retainers, then torque to spec.

**Torque Spec: 58 N·m (591 kgf·cm, 43 ft·lbf)**

**NEW Replacement Parts**

**Rear Stabilizer Bar**

Part Number	Part Name	Kit #	Qty
90080-11482	Bolt, w/ Washer	3	4

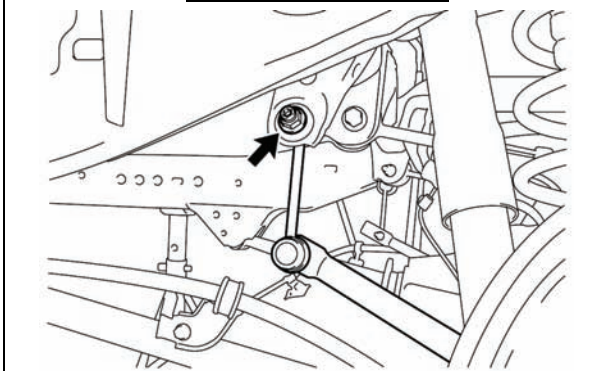

**23. RECONNECT THE REAR STABILIZER BAR**

- a) Reconnect the 2 rear stabilizer links with the 2 nuts and torque to spec.

**Torque Spec: 69 N·m (704 kgf·cm, 51 ft·lbf)**

- b) Install the 4 **NEW** bolts and 2 brackets, then torque to spec.

**Torque Spec: 37 N·m (377 kgf·cm, 27 ft·lbf)**

**NEW Replacement Parts**

**Rear Brake Flexible Hose**

Part Number	Part Name	Kit #	Qty
47351-34040	Bracket, Flexible Hose, No 5	1	1
90468-08035	Clip	1	2
91621-B0816	Bolt, w/ Washer	1	1

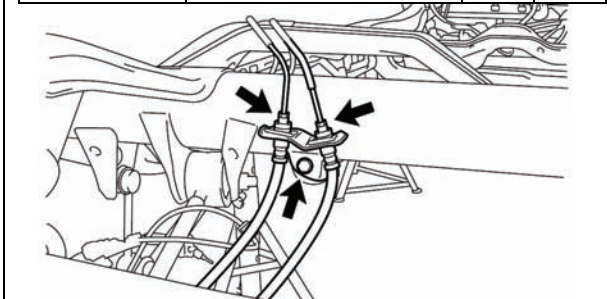

**24. RECONNECT THE REAR BRAKE FLEXIBLE HOSES**

- a) Install the No.5 flexible hose bracket with the **NEW** bolt and torque to spec.

**Torque Spec: 28 N·m (286 kgf·cm, 21 ft·lbf)**

- b) Reconnect the rear brake tubes and torque to spec.

**Torque Spec: 16 N·m (163 kgf·cm, 12 ft·lbf)**

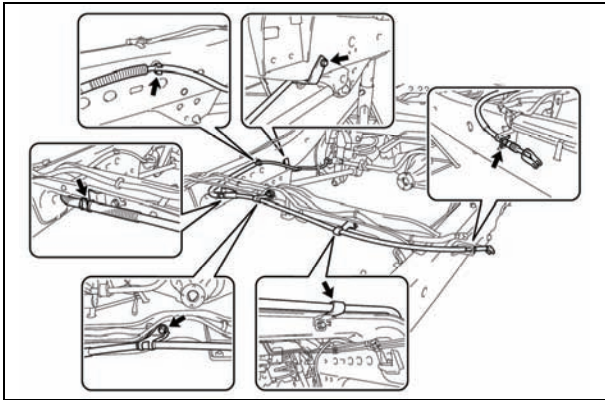

## 25. REINSTALL THE NO.2 PARKING BRAKE CABLE

- Reconnect the No.2 parking brake cable to the 3 clamps.
- Reinstall the 2 bolts and torque to spec.
- Reinstall the clip.

**Torque Spec: 26 N-m (265 kgf-cm, 19 ft-lbf)**

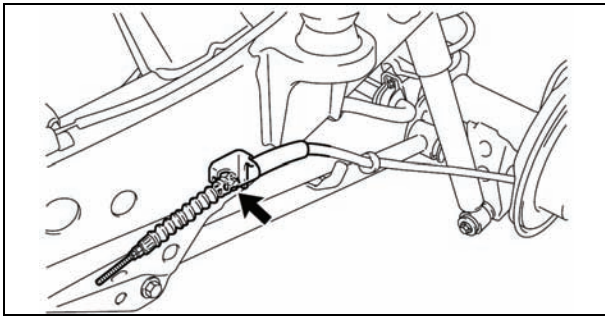

## 26. RECONNECT THE NO.3 PARKING BRAKE CABLE

- Reconnect the No.3 parking brake cable with the bolt and torque to spec.

**Torque Spec: 26 N-m (265 kgf-cm, 19 ft-lbf)**

**NEW Replacement Parts**

**Rear Wheel Speed Sensors**

Part Number	Part Name	Kit #	Qty
89545-0C020	Sensor, Speed, Rear RH	3	1
89546-0C020	Sensor, Speed, Rear LH	3	1

## 27. CONNECT THE NEW REAR SPEED SENSOR CONNECTORS

- Install the new rear speed sensor
- Route the rear speed sensor connector and wire with the 2 clamps.
- Repeat the procedure on the opposite side.

## 28. REINSTALL THE 4 WHEELS

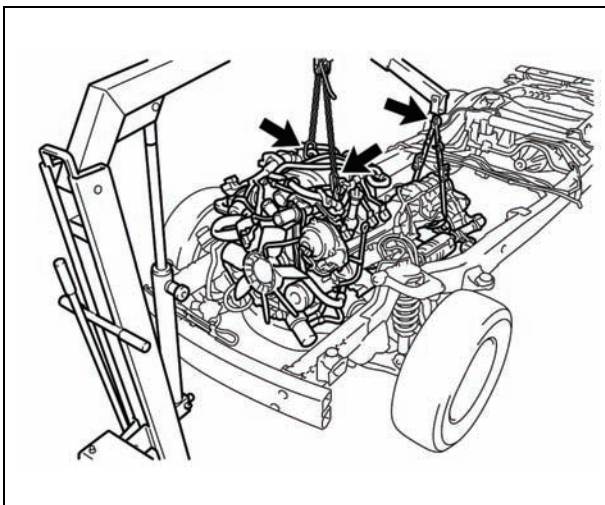

## 29. REINSTALL THE ENGINE AND TRANSMISSION ASSY

- Reinstall the engine and transmission assy.

### NOTE:

- When reinstalling the engine and transmission assy, **ALWAYS** use 2 engine hoists or mini cranes.
- DO NOT** use 1 engine hoist or mini crane to lower the engine and transmission assy, as the unbalanced weight may lead to an accident/injury.
- ONLY** use engine hoists or mini cranes that can properly support the weight of the engine and transmission assy.
- Carefully** adjust the 2 engine hoists or mini cranes so that the engine and transmission assy is properly balanced.

b) Attach the engine mounts with the 4 **NEW** nuts and torque to spec.

**Torque Spec: 38 N-m (387 kgf-cm, 28 ft-lbf)**

**NEW Replacement Parts**

**Engine Mounts**

Part Number	Part Name	Kit #	Qty
90179-10071	Nut	1	4

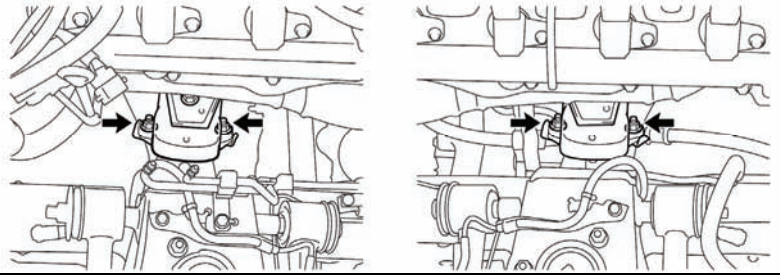

**NEW Replacement Parts**

**Transmission Mount**

Part Number	Part Name	Kit #	Qty
90080-11387	Bolt, w/ Washer	3	4

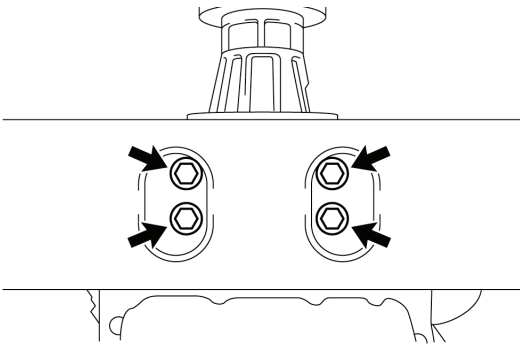

c) Attach the transmission mount with 4 **NEW** bolts and torque to spec.

**Torque Spec: 18 N-m (184 kgf-cm, 13 ft-lbf)**

d) Reinstall the items/parts that were removed during the engine and transmission assy removal.

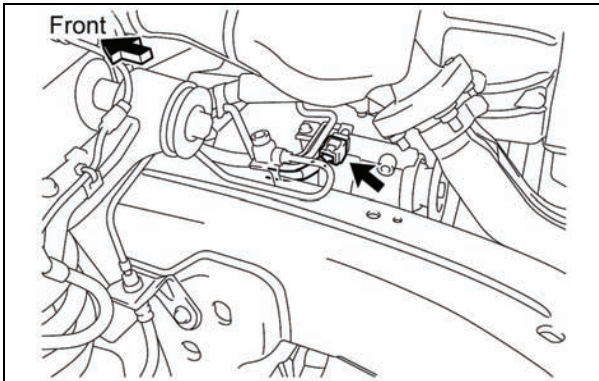

**30. RECONNECT THE A.D.D. ACTUATOR CONNECTOR (4WD ONLY)**

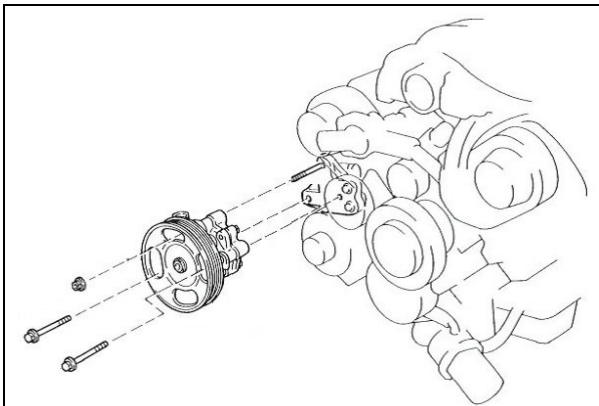

**31. REINSTALL THE POWER STEERING VANE PUMP ONTO ENGINE ASSEMBLY ASSY**

a) Reinstall the power steering vane pump assy to the mounting bracket with the 2 bolts and nut, then torque to spec.

**Torque Spec: 44 N-m (449 kgf-cm, 33 ft-lbf)**

### 32. REINSTALL THE DRIVE BELT

**NEW Replacement Parts**

Part Number	Part Name	Kit #	Qty
23232-41081	Gasket	1	1
90430-12026		1	1

### 33. RECONNECT THE FUEL PIPES AND HOSE

- Reconnect the No.1 fuel hose.
- Always use 2 **NEW** gaskets.
- Tighten the pulsation damper by hand.
- Tighten the pulsation damper to the specified torque using the SST.

**SST: 09617-24011 or equivalent**

**Torque Spec: 39 N-m (398 kgf-cm, 29 ft-lbf)**

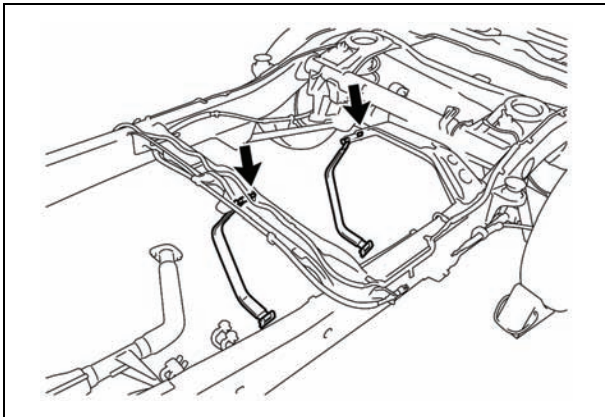

### 34. REINSTALL THE FUEL TANK STRAPS

- Reinstall the fuel tank straps with the 2 pins and 2 clips.

**NEW Replacement Parts**

**Fuel Tank Straps**

Part Number	Part Name	Kit #	Qty
90119-A0077	Bolt, w/ Washer	3	2

**No.1 Fuel Tank Protector**

Part Number	Part Name	Kit #	Qty
90080-11373	Bolt, w/ Washer	3	5

### 35. REINSTALL THE FUEL TANK

- Reinstall the fuel tank with the 2 **NEW** bolts and torque to spec.

**Torque Spec: 62 N-m (632 kgf-cm, 46 ft-lbf)**

- Reinstall the fuel tubes.
- Connect the clamp and connector(s).

### 36. REINSTALL THE NO.1 FUEL TANK PROTECTOR

- Reinstall the No.1 fuel tank protector with the **NEW** bolts and **NEW** nuts, then torque to spec.

**Torque Specs: Bolt - 29 N-m (296 kgf-cm, 21 ft-lbf)**

**NOTE:**

- The number of fuel connectors will differ depending on the vehicle specs.

### 37. REINSTALL THE EXHAUST SYSTEM

- a) Install the 3 **NEW** exhaust pipe gaskets.
- b) Reinstall the center exhaust pipe with the 4 exhaust pipe supports, 2 **NEW** flange retainers and 4 bolts, then torque to spec.

**Torque Spec: 48 N-m (489 kgf-cm, 35 ft-lbf)**

- c) Reinstall the tail exhaust pipe with the 2 tail pipe brackets.
- d) Face the clamp in the direction indicated in the illustration, and torque to spec.

**Torque Spec: 32 N-m (326 kgf-cm, 24 ft-lbf)**

#### NEW Replacement Parts

##### Exhaust System

Part Number	Part Name	Kit #	Qty
18495-38020	Retainer, Converter RR Flange	1	2
90080-43034	Gasket, Exhaust System**	NA*	2
90080-46263	Clamp	3	1
90917-06083	Gasket, Exhaust System**	NA*	2
90917-06085	Gasket Exhaust System	1	1

\*Individual Part(s)

\*\*Only 1 part # is used. The part # varies depending on vehicle model year.

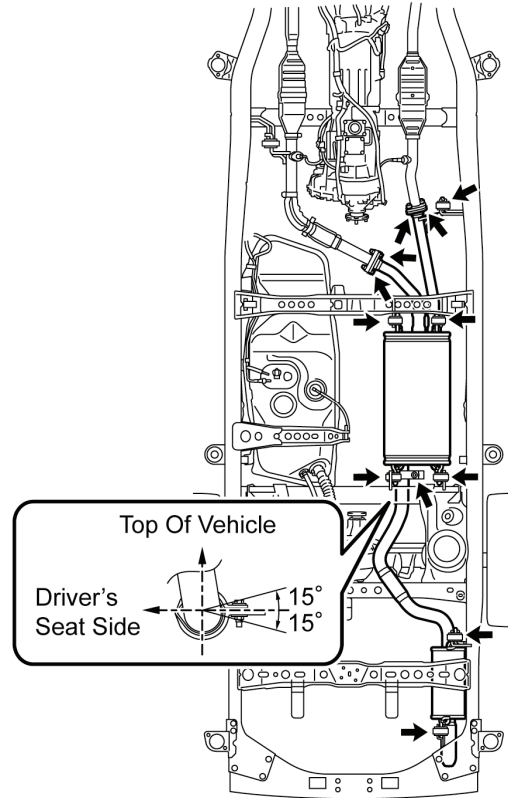

### 38. REINSTALL THE FRONT PROPELLER SHAFT (4WD ONLY)

- a) Aligning the matchmarks, install the front propeller shaft to the transfer case and the front differential with the 8 bolts, 8 washers and 8 nuts, then torque to spec.

**Torque Spec: 74 N-m (755 kgf-cm, 55 ft-lbf)**

#### NEW Replacement Parts Receiver Hitch

Part Number	Part Name	Kit #	Qty
90080-11491	Bolt, w/ Washer	3	6
90080-11492		3	4

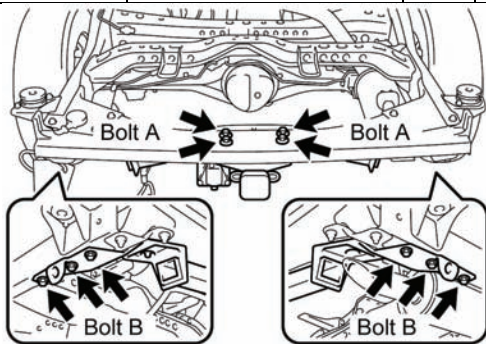

### 39. REINSTALL THE RECEIVER HITCH BRACKET SUB-ASSY (IF EQUIPPED)

- a) Reinstall the receiver hitch bracket sub-assy with the 10 **NEW** bolts and torque to spec.

**Torque Spec: Bolt A - 105 N-m (1071 kgf-cm, 78 ft-lbf)**

**Torque Spec: Bolt B - 105 N-m (1071 kgf-cm, 78 ft-lbf)**

### NEW Replacement Parts

#### Spare Tire Carrier

Part Number	Part Name	Kit #	Qty
90080-11180	Bolt, w/ Washer	3	4
51900-0C020	Spare Tire Carrier	NA*	1

\*Individual Part(s)

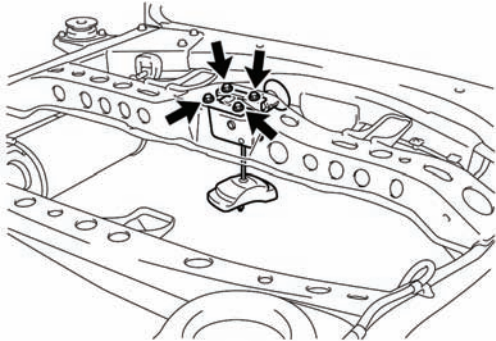

### 40. INSTALL THE SPARE TIRE CARRIER

- Install the **NEW** spare tire carrier with the 4 **NEW** bolts and torque to spec.

**Torque Spec: 20 N·m (204 kgf·cm, 15 ft·lbf)**

**NOTE:**

Install the spare wheel after tightening the rear suspension arms.

### 41. REMOVE THE FRAME FROM THE LIFT

- Remove the ratcheting tie down strap from the frame.
- Lower the frame to the ground.

### G. REINSTALL THE CAB BODY ASSY

### NEW Replacement Parts

Part Number	Part Name	Kit #	Qty
47313-0C012	Tube, FR Brake, No 3	3	1
47316-0C040	Tube, FR Brake, No 6	NA*	1
47322-0C030	Tube, FR Brake, No 2	NA*	1
47325-0C020	Tube, FR Brake, No 5	NA*	1

\*Individual Part(s)

### 1. INSTALL THE **NEW** ENGINE COMPARTMENT BRAKE LINE

- Install the **NEW** No.3 and **NEW** No.6 front brake tubes.
- Install the **NEW** No.2 and **NEW** No.5 rear brake tubes.
- Torque all brake tubes to spec.

**Torque Spec: 16 N·m (163 kgf·cm, 12 ft·lbf)**

**NOTE:**

The number of clamps will differ depending on the vehicle spec.



## 2. REINSTALL THE CAB BODY ASSY

- Raise the cab assy high enough so that the top of the engine clears the lowest point of the cab.
- Push the frame under the cab assy.

**Note: Line up the wheels with the alignment marks previously made to help align the frame with the cab.**

- Lower the cab assy slowly, making sure it does not interfere with anything.
- Adjust the vehicle's frame as needed to align the cab mounts with the cab assy bolts.
- Once the cab assy is set on the mounts, secure it to the frame with the 8 bolts, 8 nuts and 8 washers and torque to spec.

**Torque Specs: No.1 and No.4 Nut - 47 N·m (479 kgf·cm, 35 ft·lbf)**

**Torque Specs: No.2 Nut - 54 N·m (551 kgf·cm, 40 ft·lbf)**

**Torque Specs: No.3 Nut - 67 N·m (683 kgf·cm, 50 ft·lbf)**

### NOTE:

- **DO NOT** work directly underneath the vehicle when pushing the frame under the cab assy.
- **Slowly** lower the cab body assy while making sure that the wire harness, steering shaft and hoses do not interfere with it.
- **With 2 to 3 people** checking for interference, slowly lower the cab body assy to the frame.
- **Center** the vehicle's weight on the lift arms so that it does not slant/tilt to one side.

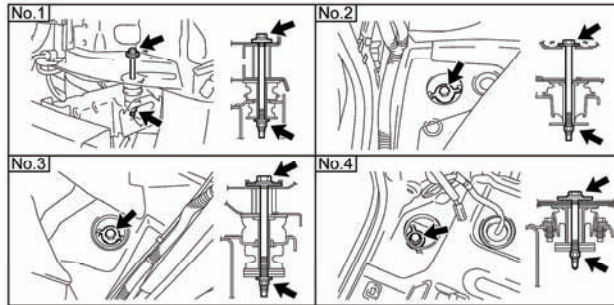
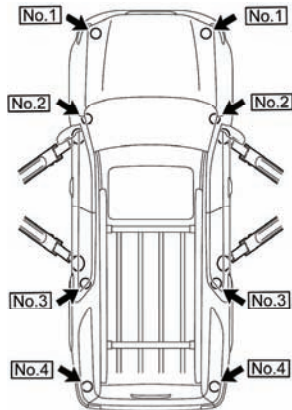

## 3. READJUST LIFT ARMS AND LIFT VEHICLE

## 4. REMOVE THE FRONT WHEELS

## 5. RECONNECT THE FRONT SPEED SENSOR CONNECTORS

- Reconnect the front speed sensor connector.
- Reinstall the clamp.
- Repeat the procedure on the opposite side.

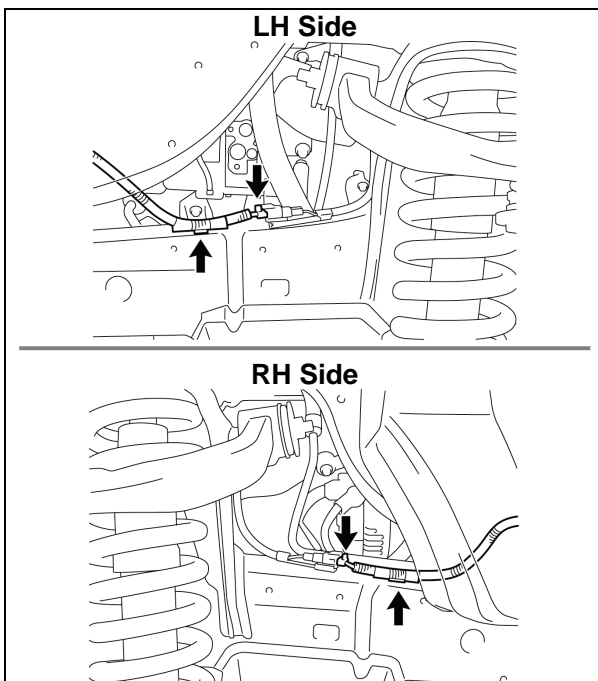

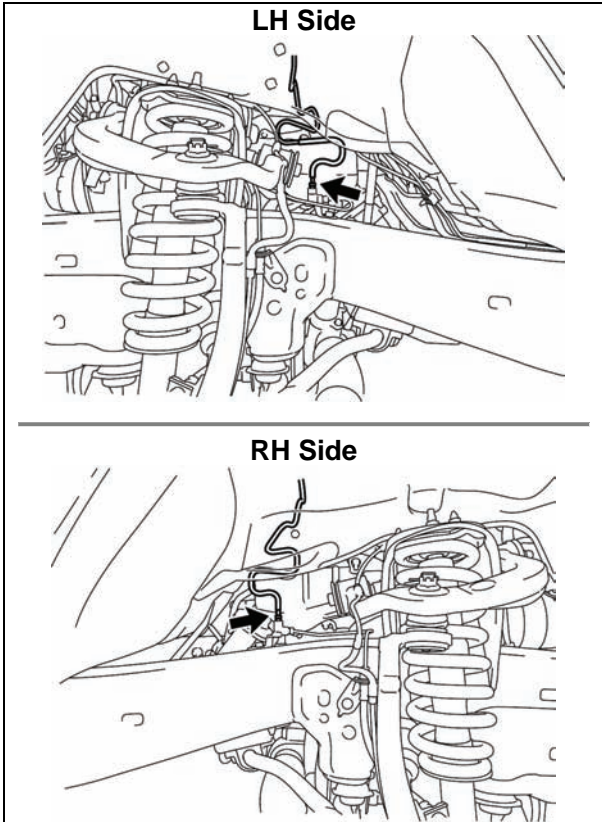

**6. RECONNECT THE FRONT BRAKE TUBES**

- a) Reconnect the front brake tube and torque to spec.
- b) Repeat the procedure on the opposite side.

**Torque Spec: 16 N·m (163 kgf·cm, 12 ft·lbf)**

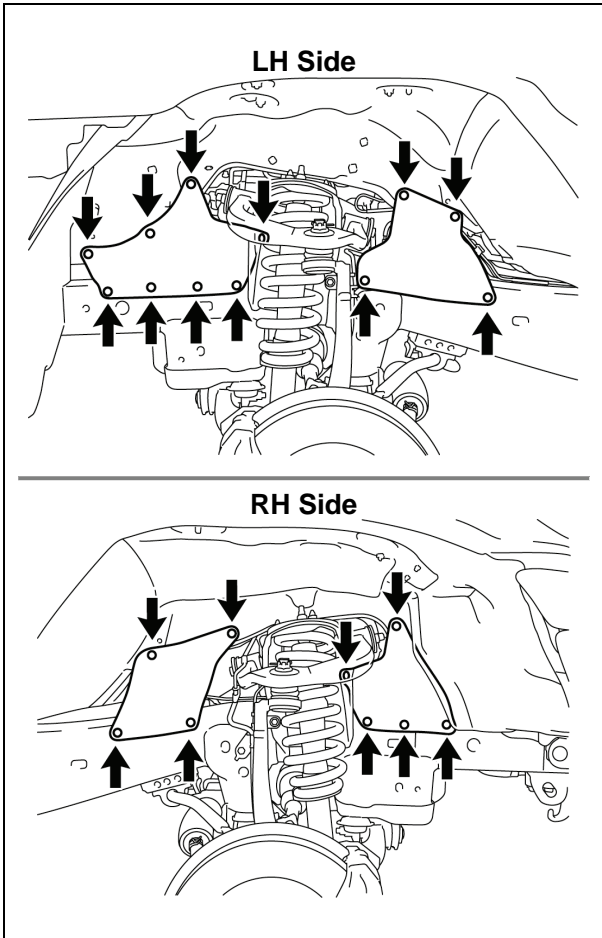

**7. REINSTALL THE FRONT FENDER APRON SEALS**

- a) Reinstall the 4 front fender apron seals with the 21 clips.

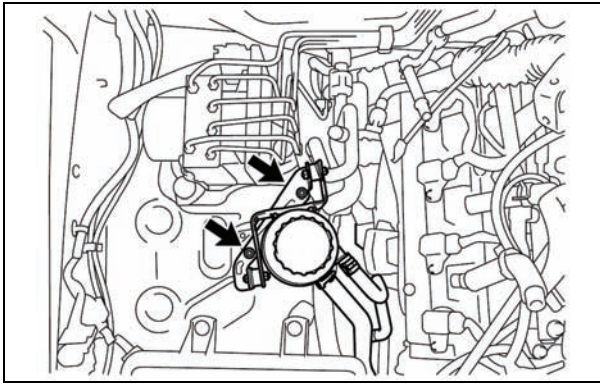

### 8. RECONNECT THE VANE PUMP OIL RESERVOIR

- a) Reinstall the vane pump oil reservoir with the 2 nuts and torque to spec.

**Torque Spec: 8.0 N-m (82 kgf-cm, 71 in-lbf)**

### 9. RECONNECT THE HEATER WATER HOSE

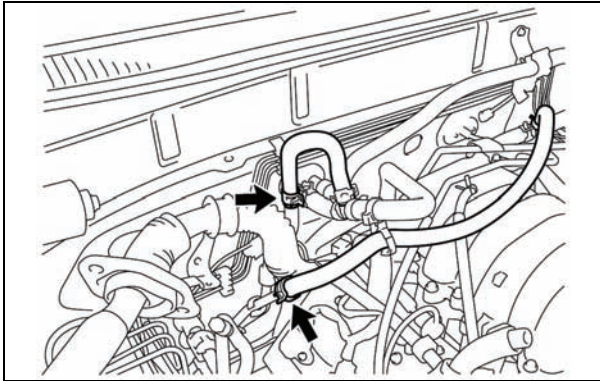

### 10. RECONNECT THE REAR HEATER WATER HOSES (IF EQUIPPED)

- a) Reconnect the 2 rear heater water hoses to the water pipe.

### NEW Replacement Parts

#### A/C Line O-Rings

Part Number	Part Name	Kit #	Qty
90069-08007	Ring, O	3	1
90069-08009		1 - 3	1

### 11. RECONNECT THE A/C DISCHARGE HOSE AND SUCTION HOSE

- a) Install the **NEW** O-rings to the discharge hose and suction hose.
- b) Reinstall the discharge hose and suction hose with the nuts and torque to spec.

**Torque Spec: 10 N-m (102 kgf-cm, 7 ft-lbf)**

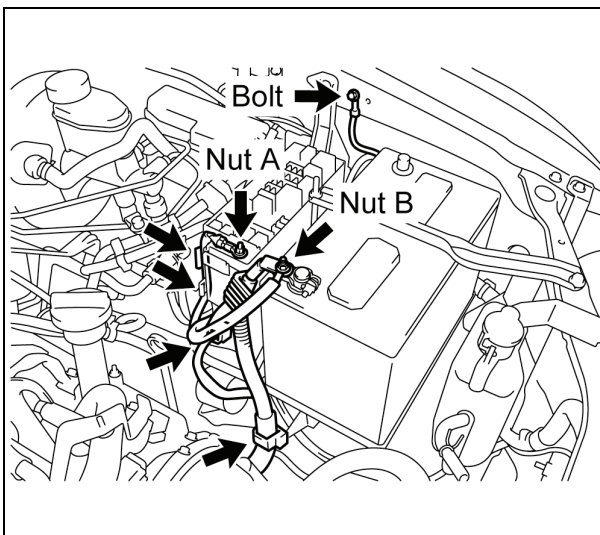

### 12. RECONNECT THE NO.2 ENGINE WIRE HARNESS

- a) Reinstall the No.2 engine wire harness with the nut and torque to spec.
- b) Reconnect the No.2 engine wire harness to the 2 clamps of the junction block.
- c) Reinstall the nut and reconnect the positive (+) battery cable and torque to spec.
- d) Reinstall the bolt and reconnect the ground wire to the LH side inner fender and torque to spec.
- e) Reconnect the connector and clamp.
- f) Reinstall the fuel pump relay.
- g) Reinstall the relay block cover.

**Torque Specs: Nut A - 10 N-m (102 kgf-cm, 7 ft-lbf)**

**Torque Specs: Nut B - 13 N-m (133 kgf-cm, 10 ft-lbf)**

**Torque Specs: Bolt - 8.0 N-m (82 kgf-cm, 71 in-lbf)**

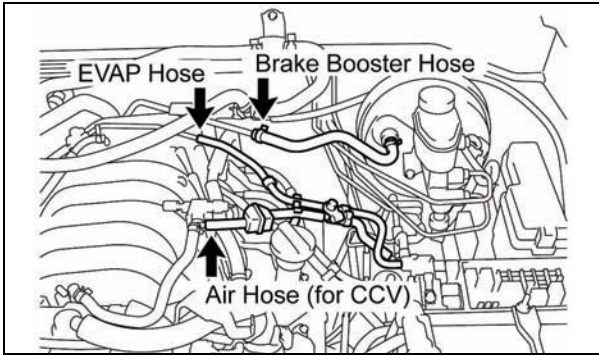

### 13. RECONNECT THE FOLLOWING ENGINE COMPARTMENT HOSES

- Reconnect the EVAP hose
- Reconnect the air hose (for CCV)
- Reconnect the brake booster hose.

**NEW Replacement Parts**

**Drain Cock O-Ring**

Part Number	Part Name	Kit #	Qty
16492-21050	Ring, O Radiator	1	1

### 14. REINSTALL THE RADIATOR

- Install the **NEW** radiator drain cock plug O-ring.
- Tighten the radiator drain cock plug.
- Reinstall the radiator with the 4 bolts and torque to spec.

**Torque Spec: 12 N·m (122 kgf·cm, 9 ft·lbf)**

- Reconnect the upper and lower radiator hoses, automatic transmission cooler hoses.
- Reinstall the fan shroud.
- If equipped** re-install external transmission cooler

### 15. RECONNECT THE ACCELERATOR CONTROL CABLE (ONLY FOR VEHICLES PRODUCED ON OR BEFORE SEPTEMBER 2002)

### 16. REINSTALL THE FOLLOWING PARTS

- Air Cleaner
- Throttle Body Cover
  - **Torque Spec: Nut - 8.0 N·m (82 kgf·cm, 71 in·lbf)**

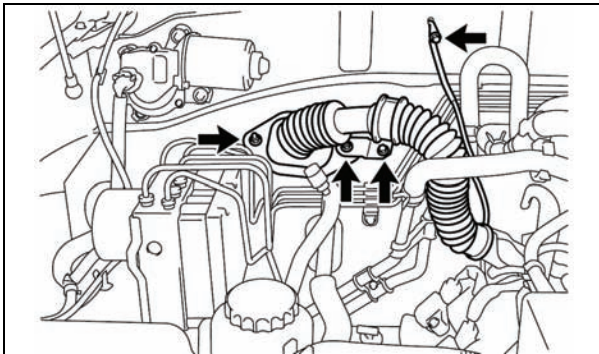

### 17. RECONNECT THE ENGINE WIRE HARNESS

- Reinstall the engine wire harness connector with the 2 nuts and torque to spec.
- Reinstall the bolt and torque to spec.

**Torque Spec: 8.0 N·m (82 kgf·cm, 71 in·lbf)**

- Reconnect the ground wire to the cowl panel with the bolt and torque to spec.

**Torque Spec: 8.0 N·m (82 kgf·cm, 71 in·lbf)**

**NEW Replacement Parts**

**Rear Bumper Extension**

Part Number	Part Name	Kit #	Qty
90178-08011	Nut, Flange	1	4
90119-A0064	Bolt, w/ Washer	3	4

### 18. REINSTALL THE REAR BUMPER EXTENSION MOUNTING BRACKET W/ BACK STEP REINFORCEMENT

- Reinstall the rear bumper extension mounting bracket w/ back step reinforcement with the 4 **NEW** nuts and torque to spec.
- Install the 4 **NEW** bolts and torque to spec.

**Torque Spec: 19 N·m (194 kgf·cm, 14 ft·lbf)**

## 19. REINSTALL THE FOLLOWING REAR BODY COMPONENTS

- Rear Bumper Cover
  - **Torque Spec: 7.0 N-m (71 kgf-cm, 62 in-lbf)**
- Rear Quarter Panel Mudguard LH/RH

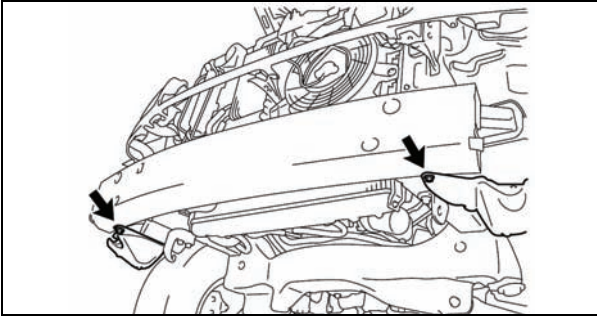

## 20. RECONNECT THE FRONT FENDER LINER

- a) Reconnect the front fender liners with the 2 screws.

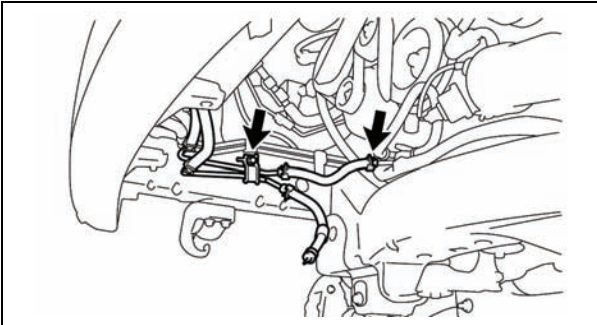

## 21. RECONNECT THE AUTOMATIC TRANSMISSION NO.2 OIL COOLER OUTLET TUBE

- a) Reinstall the No.2 oil cooler outlet tube with the bolt and torque to spec.
- b) Reconnect the hose.

**Torque Spec: 12 N-m (122 kgf-cm, 9 ft-lbf)**

### NEW Replacement Parts

#### Side Step Assy LH/RH

Part Number	Part Name	Kit #	Qty
90179-08068	Nut	1	6
90119-08516	Bolt, w/ Washer	1	10

## 22. REINSTALL THE FOLLOWING FRONT BODY PARTS

- Front Bumper Energy Absorber
- Front Bumper Cover
  - **Torque Spec: 7.0 N-m (71 kgf-cm, 62 in-lbf)**
- Front Fender Mudguard LH/RH
- Side Step Assy LH/RH with the 10 new bolts and 6 new nuts.
  - **Torque Spec: 20 N-m (204 kgf-cm, 15 ft-lbf)**

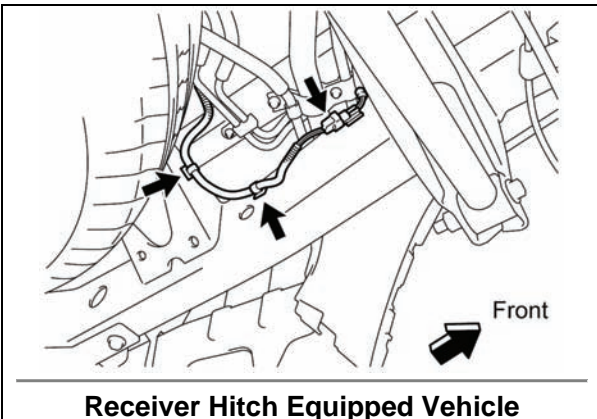

## 23. RECONNECT THE FRAME WIRE

- a) Reconnect the connector and clamp(s) (*For Charcoal Canister*).
- b) Reconnect the connector(s) and clamp(s) (*Receiver Hitch Equipped Vehicles Only*).

### NOTE:

The number of fastening connectors and clamps for the frame wire will differ depending on the vehicle model. Please verify the current vehicle and continue.

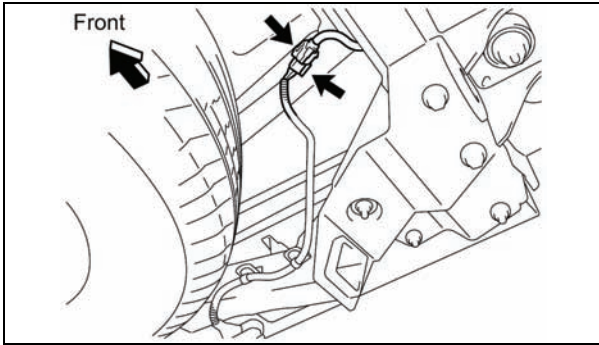

**NEW Replacement Parts**

**Fuel Tank Filler and Breather Hose Clamps**

Part Number	Part Name	Kit #	Qty
90460-22001	Clamp, Hose	1	2
90460-46005		1	2

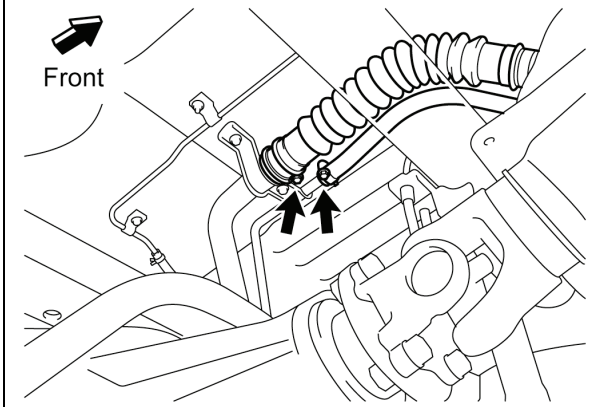

**24. RECONNECT THE FUEL TANK TO FILLER PIPE HOSE AND FUEL TANK BREATHER HOSE**

- a) Reconnect the fuel tank to filler pipe hose with the 2 **NEW** clamps.
- b) Reconnect the fuel tank breather hose with the 2 **NEW** clamps.

**NOTE:**

- Tighten the clamp of the fuel tank to filler pipe hose until it comes into contact with the stopper.

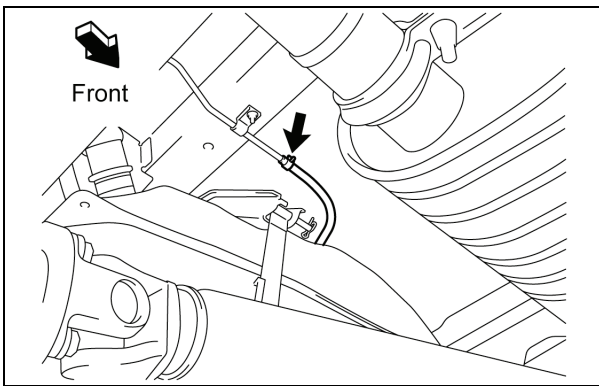

**25. RECONNECT THE FUEL TANK VENT HOSE**

**NOTE:**

After finishing the connection, check whether the pipe and the connector are securely connected by pulling them.

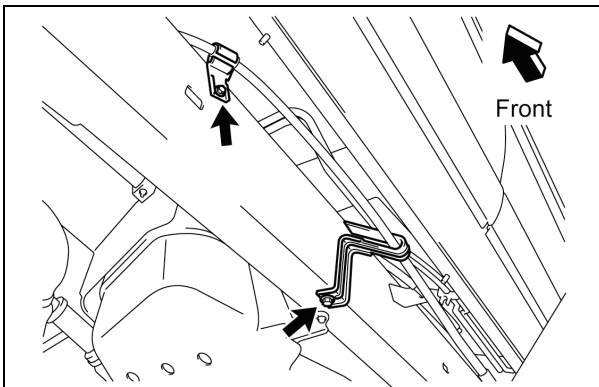

**26. RECONNECT THE NO.1 PARKING BRAKE CABLE**

- a) Reconnect the No.1 parking brake cable with the bolt and torque to spec.
- b) Reinstall the cable support bracket with the bolt and torque to spec.

**Torque Spec: 26 N·m (265 kgf·cm, 19 ft·lbf)**

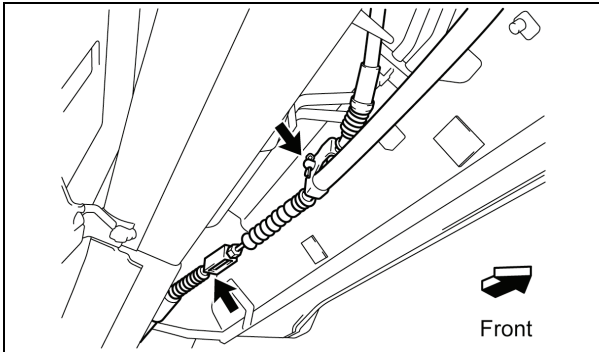

- c) Reconnect the No.2 parking brake cable with the clip and pin.
- d) Reconnect the No.1 parking brake cable to the No.3 parking brake cable and torque to spec.

**Torque Spec: 8.0 N-m (82 kgf-cm, 71 in-lbf)**

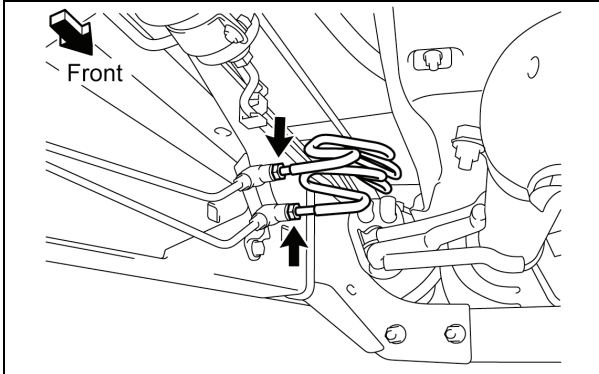

**27. RECONNECT THE REAR BRAKE TUBES**

- a) Using a flare nut wrench, connect the 2 rear brake tubes and torque to spec.

**Torque Spec: 16 N-m (163 kgf-cm, 12 ft-lbf)**

**NEW Replacement Parts  
Intermediate Shaft**

Part Number	Part Name	Kit #	Qty
90080-11555	Bolt, w/ Washer	3	2

**28. RECONNECT THE NO.2 STEERING INTERMEDIATE SHAFT**

- a) Make sure the spindles are in a straight-ahead position and the steering wheel is centered.
- b) Aligning the matchmarks, connect the No.2 steering intermediate shaft to the steering sliding yoke with the **NEW** bolt (A).
- c) Aligning the matchmarks, connect the No.2 steering intermediate shaft to the control valve shaft with the **NEW** bolt (B).
- d) Torque all bolts to spec.

**Torque Spec: 35 N-m (357 kgf-cm, 26 ft-lbf)**

**NEW Replacement Parts  
Auto Transmission Control Cable**

Part Number	Part Name	Kit #	Qty
90179-08054	Nut	1	1
90201-09019	Washer, Plate	1	1

**29. RECONNECT THE TRANSMISSION CONTROL CABLE**

- a) Reinstall the bolt and connect the transmission control cable and torque to spec.

**Torque Spec: 18 N-m (184 kgf-cm, 13 ft-lbf)**

- b) Reinstall the pin or **NEW** nut and **NEW** washer, then torque to spec.

**Torque Spec: Nut- 13 N-m (133 kgf-cm, 10 ft-lbf) (Only For Vehicles Produced On Or Before June 2003)**

**Torque Spec: Nut- 15 N-m (153 kgf-cm, 11 ft-lbf) (Only For Vehicles Produced After June 2003)**

**NOTE: Vehicles produced after August 2003 is not equipped with washer.**

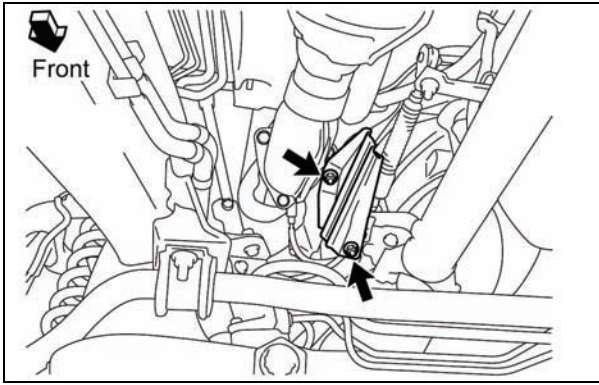

- c) Reinstall the transmission control cable insulator with the 2 nuts and torque to spec.

**Torque Spec: 5.0 N·m (51 kgf·cm, 44 in·lbf)**

**30. REINSTALL FRONT WHEELS  
31. LOWER THE VEHICLE**

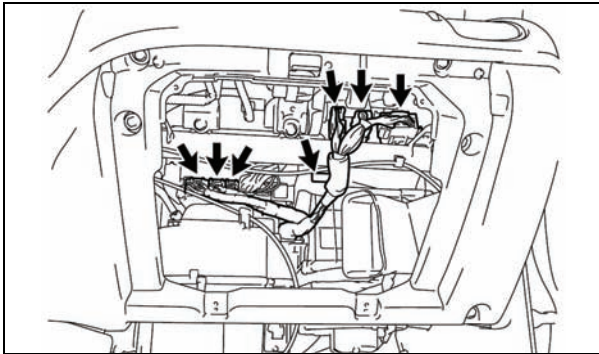

**32. RECONNECT THE ENGINE WIRE HARNESS**

- a) Reconnect the connectors and clamp.

**NOTE:**

- The number of connectors will differ depending on the vehicle specs.
- Incorrectly connected connectors may cause the engine to start improperly. Be certain that the connectors are correctly connected.

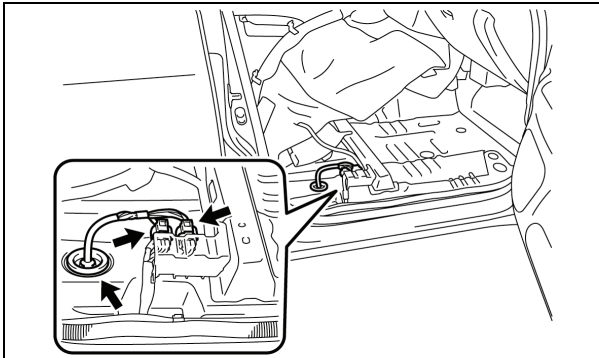

**33. RECONNECT THE FRAME WIRE CONNECTOR**

- a) Reinstall the frame wire harness grommet.  
b) Reconnect the 2 connectors.

**34. REINSTALL THE FOLLOWING INTERIOR COMPONENTS**

- a) Glove Compartment
- No.4 Heater To Register Duct
  - Lower No.2 Instrument Finish Panel
  - Glove Compartment Door
- b) Center Console (**4WD Only**)
- Transfer High and Low Shift Lever
  - No.1 Shift and Select Lever Boot
    - **Torque Spec: 7.0 N·m (71 kgf·cm, 62 in·lbf)**
  - Upper Console Panel
  - Shifting Hole Cover
  - Transfer Shift Lever Knob
- c) Front Seat and Trim
- Front Seat RH
    - **Torque Spec: 37 N·m (377 kgf·cm, 27 ft·lbf)**
  - Cowl Side Trim Board LH/RH
  - Front Door Scuff Plate LH/RH



- d) Rear Passenger and Cargo Area
  - Rear Door Scuff Plate LH/RH
  - Rear Quarter Trim Panel LH/RH
  - Rear Floor Mat Support Plate
  - Rear No.2 Seat Outer Belt Floor Anchor **(If Equipped)**
    - **Torque Spec: 42 N·m (428 kgf·cm, 31 ft·lbf)**
  - Rear No.1 Seat Outer Belt Floor Anchor
    - **Torque Spec: 42 N·m (428 kgf·cm, 31 ft·lbf)**
  - Rear 3<sup>rd</sup> Row Seat **(If Equipped)**
  - Put 2<sup>nd</sup> Row Seat back into place

### 35. PUT THE REAR NO.1 SEATS BACK INTO PLACE

#### H. FINAL ASSEMBLY

#### 1. RECONNECT THE NEGATIVE BATTERY TERMINAL CABLE

**NEW Replacement Parts**

**Front Differential Gaskets (4WD Only)**

Part Number	Part Name	Kit #	Qty
12157-10010	Gasket, Drain Plug	NA*	1
90430-24003	Gasket	NA*	1

#### 2. REFILL THE FOLLOWING

- a) Brake Fluid
  - Fill with Toyota DOT 3 Brake Fluid.
  - Remove the brake lines from the master cylinder.
  - Bleed the master cylinder.
  - Reinstall the brake lines to the master cylinder and torque to spec.
    - **Torque Spec: 16 N·m (163 kgf·cm, 12 ft·lbf)**
  - Bleed the brake system at each wheel and torque the bleeder screws to spec.
    - **Torque Spec: 11 N·m (112 kgf·cm, 8 ft·lbf)**
  - Top off brake fluid
- b) Coolant
  - Refill with Toyota Long Life Coolant.
- c) Front Differential **(4WD Only)**
  - Install the NEW drain plug gasket and torque to spec.
  - Torque Spec: 65 N·m (663 kgf·cm, 48 ft·lbf)
  - Refill with Hypoid Gear Oil API GL-5 75W-90.
  - Install the NEW filler plug gasket and torque to spec.
    - **Torque Spec: 39 N·m (398 kgf·cm, 29 ft·lbf)**
- d) Recharge A/C System

#### 3. START THE VEHICLE AND PERFORM AND INSPECT THE FOLLOWING

- Fuel System
  - Start the engine and let it run for 5 seconds, and then stop the engine and inspect for leaks.
  - If there are no leaks, restart the engine and re-inspect.
- Bleed Cooling System and Check for Leaks
- Brake System Leaks
- Front Differential System
- Operation of A/C System

#### 4. INSPECT FOR A/C REFRIGERANT LEAKS

**5. CHECK THE OPERATION OF THE FOLLOWING ITEMS AND ADJUST AS NEEDED**



**Make sure to follow the procedure outlined in the appropriate repair manual for the vehicle you are working on when checking, and if needed, adjusting the operation of the items listed below. This is an important step, and must be performed thoroughly to ensure proper operation of these items.**

- Parking Brake Lever Travel
- Shift Control Lever

**6. CHECK ALL FLUID LEVELS AND ADJUST AS NEEDED**

**NEW Replacement Parts**

**Rear Lateral Control Rod**

Part Number	Part Name	Kit #	Qty
90179-14062	Nut	1	1

**7. REINSTALL AND TORQUE THE REAR LATERAL CONTROL ROD**

**Torque Specs:**

**Nut: 140 N-m (1428 kgf-cm, 103 ft-lbf)**

**Bolt: 130 N-m (1326 kgf-cm, 96 ft-lbf)**

**NOTE:**

- After stabilizing the suspension, torque the nut.
- Perform tightening with the vehicle grounded.

**8. TORQUE THE BOLTS AND NUTS OF THE REAR SUSPENSION ARMS TO SPEC**

**Torque Specs: No.1 Rear Suspension Arm (Nut) - 140 N-m (1428 kgf-cm, 103 ft-lbf)**

**Torque Specs: Bolt Of Lower Control Arm (Bolt) - 130 N-m (1326 kgf-cm, 96 ft-lbf)**

**NOTE:**

- After stabilizing the suspension, torque the bolt and nut.
- Perform tightening with the vehicle grounded.

**9. REINSTALL THE SPARE WHEEL**

**NEW Replacement Parts**

**Front Axle**

Part Number	Part Name	Kit #	Qty
95381-04045	Pin, Cotter	NA*	2

\*Individual Part(s)

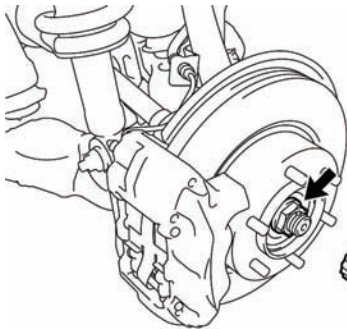

**10. TORQUE THE FRONT AXLE NUTS (4WD ONLY)**

- Remove the front wheels.
- Torque the front axle nuts to spec.

**Torque Spec: 235 N-m (2396 kgf-cm, 173 ft-lb)**

- Reinstall the lock cap with the **NEW** cotter pin.
- Reinstall the grease cap.
- Repeat the procedure on the opposite side.
- Reinstall the front wheels and torque to spec.

**Torque Spec: 112 N-m (1142 kgf-cm, 83 ft-lbf)**

**NOTE:**

**If the holes for the cotter pin are not aligned, tighten the axle nut further, up to 60°.**

**11. PERFORM A WHEEL ALIGNMENT**

**12. CHECK THE HEADLIGHT AIM AND ADJUST AS NEEDED**

## NEW Replacement Parts

### Engine Under Cover

Part Number	Part Name	Kit #	Qty
90080-11373	Bolt, w/ Washer	3	5

## 13. REINSTALL THE NO.1 ENGINE UNDER COVER

- a) Install the No.1 engine under cover with the **NEW** bolts and torque to spec.

**Torque Spec: 29 N·m (296 kgf·cm, 21 ft-lbf)**

## 14. CHECK FOR DTCS AND REPAIR AS NEEDED

## 15. PERFORM INITIALIZATION

## 16. FINAL INSPECTION

- a) Check the operation of the following systems:

- 4WD System (**4WD Only**)
- Interior Lights
- Exterior Lights
- HVAC System
- Audio System
- Power Windows
- Power Door Locks
- All Gauges, Indicators and Warning Lights
- Cooling Fans
- Vehicle Height
- Etc.

## 17. TEST DRIVE THE VEHICLE

### ◀ VERIFY REPAIR QUALITY ▶

- Confirm the all precautions are followed when servicing the vehicle
- Confirm the all system work properly and a test drive is conducted to ensure proper vehicle operation

**If you have any questions regarding this LSC, please contact your regional representative**

## VI. APPENDIX

As required by Federal Regulations, please make sure all recalled parts (original parts) removed from the vehicle are disposed of in a manner in which they will not be reused. Adequate time has been provided in the repair time to cut up and dispose of the perforated frame.