



**Technical Service  
BULLETIN**

December 7, 2007

Title:

**SPEAKER GRILLES ON REAR PACKAGE  
TRAY CRACKING**

Models:

'02 – '06 Camry

**BODY**  
**BO019-07**

**Introduction** Some 2002 – 2006 model year Camry customers may complain that the speaker grilles on the rear package tray may be cracking. Use the following repair procedure to correct this condition.

- Applicable Vehicles**
- **2002 – 2006** model year **Camry** vehicles.

**Parts  
Information**

CURRENT PART NUMBER	PART NAME	QTY
04007-521AA-B0	Grille, Replacement SSP (Gray)	1
04007-521AA-E0	Grille, Replacement SSP (Oak)	1

**NOTE:**

A repair kit consisting of just the speaker grilles and some fasteners has been made available to correct this condition (One repair kit contains material to replace both speaker grilles [LH & RH grille and 10 push nuts]).

**Warranty  
Information**

OP CODE	DESCRIPTION	TIME	OFP	T1	T2
BO7002	Install Speaker Grille Repair Kit	0.7	64330-AA160-#1	67	12

**Applicable Warranty\*:**

This repair is covered under the Toyota Comprehensive Warranty. This warranty is in effect for 36 months or 36,000 miles, whichever occurs first, from the vehicle's in-service date.

\* Warranty application is limited to correction of a problem based upon a customer's specific complaint.



**Disassembly Procedure**

1. Remove the rear seat cushion assembly.  
Refer to the Technical Information System (TIS), 2002 – 2006 model year Camry Repair Manual, *Vehicle Interior – Rear Seat – “Rear Seat – Overhaul”*.

2. Remove the roof side garnish inner RH (without curtain shield airbag).
  - A. Using a screwdriver, remove the roof side garnish inner.

**HINT:**

Tape the screwdriver tip before use.

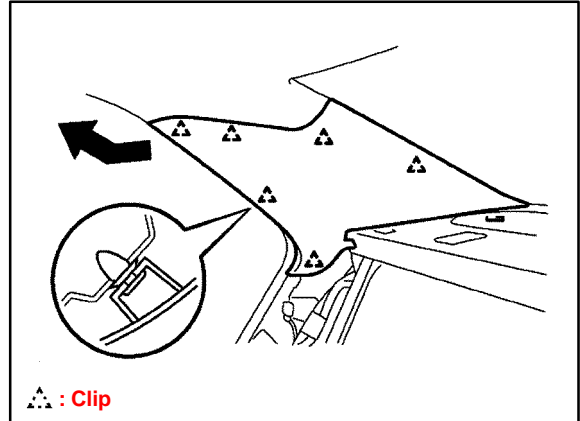

3. Remove the roof side garnish inner LH (without curtain shield airbag).
4. Remove the roof side garnish inner RH (with curtain shield airbag).
  - A. Using a screwdriver, remove the roof side garnish inner cover.
  - B. Remove one bolt behind the cover.

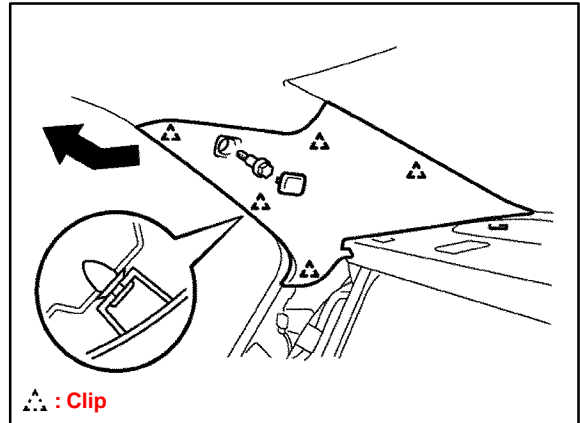

5. Remove the roof side garnish inner LH (with curtain shield airbag).
6. Remove the center stop lamp assembly.  
Refer to TIS, 2002 – 2006 model year Camry Repair Manual: *Vehicle Interior – Lighting – “Center Stop Assembly – Replacement”*.

7. Remove the rear seat shoulder belt cover RH.
  - A. Using a screwdriver, disengage the claws in the front side.
  - B. Pull out the shoulder belt cover to the front side to disengage the claws.
  - C. Pull out the shoulder belt from the slit to remove the shoulder belt cover.

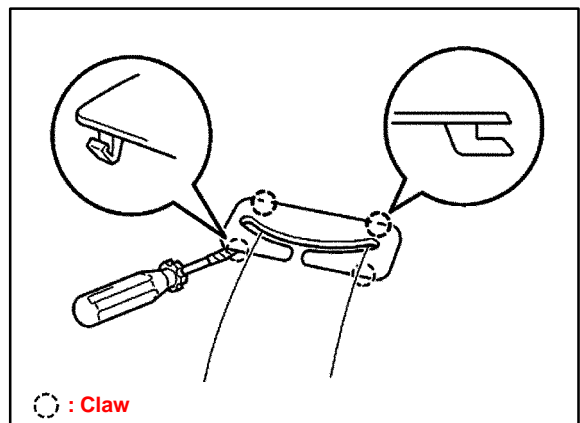

- Disassembly Procedure**
- (Continued)
8. Remove the rear side seat back assembly RH.
  9. Remove the rear side seat back assembly LH.

10. Remove the room partition board assembly.  
Remove the 9 clips and room partition board.

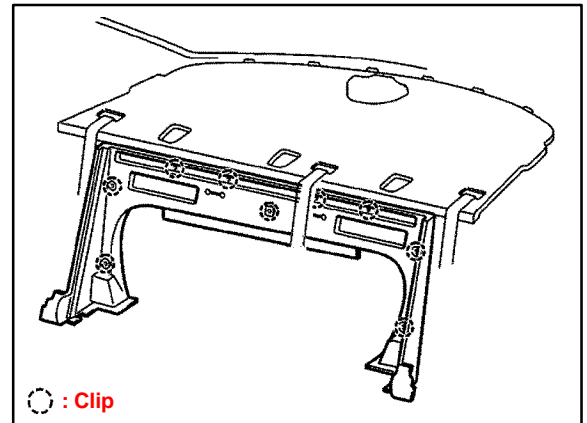

11. Remove the package tray trim panel assembly.
  - A. Remove the 3 bolts and floor anchor of the seat belt.
  - B. Disengage the clips and claws and pull out the belt to remove the package tray trim.

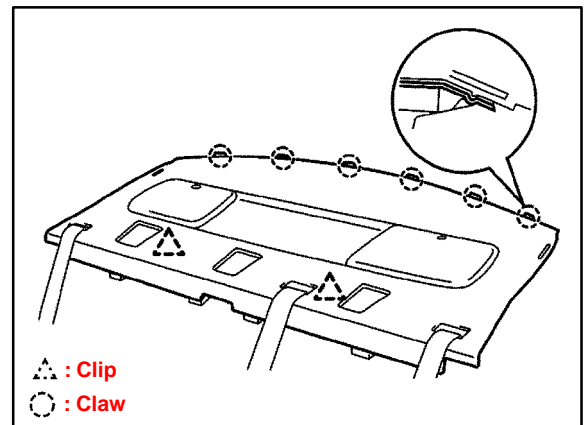

**Repair Procedure**

1. From the underside of the package tray, drill out the old speaker grille.  
Use an 8 mm (5/16 inch) drill bit, to drill out the heat-staked speaker grille at the five locations.

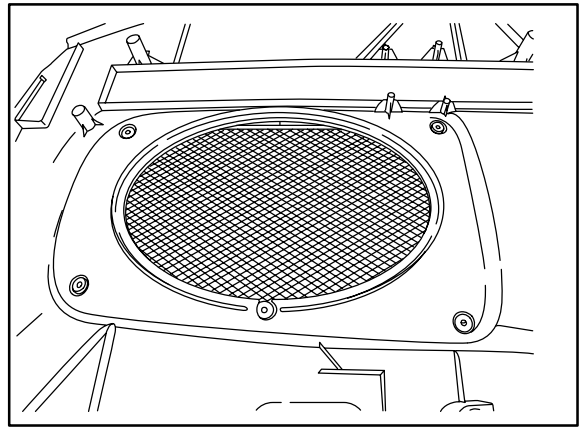

2. Install the NEW speaker grille and fasten in place using the push lock nuts provided in the repair kit.

**HINT:**

Use a small deep socket to push the nuts firmly in place.

**NOTE:**

Make sure that there are **NO** gaps between the speaker grille and package tray.

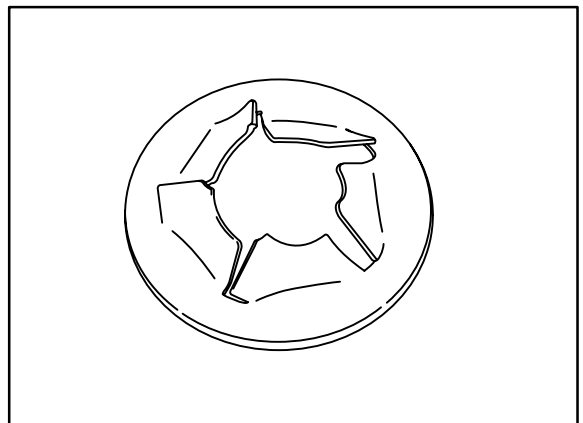
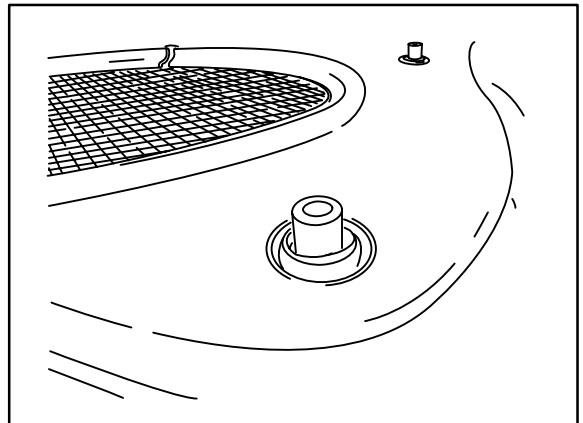

3. Reassemble in reverse order of disassembly.