

Charging System Inoperative

Service Category Power Source/Network

Section Battery/Charging

Market USA

Toyota Supports
 ASE Certification 

Applicability

YEAR(S)	MODEL(S)	ADDITIONAL INFORMATION
2011	Avalon, RAV4, Venza	
2011 – 2012	Camry, Highlander, Sienna	

Introduction

Some 2011 – 2012 model year vehicles with 2AR or 2GR engines may exhibit insufficient charging performance from the alternator. An updated pulley assembly is available to address this condition.

Parts Information

ENGINE	MODEL	MODEL YEAR	PREVIOUS PART NUMBER	CURRENT PART NUMBER	PART NAME	QTY
2AR	RAV4	2011	27415-0W020	Same	Pulley, Alternator w/Clutch	1
	Camry	2011	27415-0W120	Same		1
		2012	27415-0W020	Same		
2GR	All	2011–2012	27415-0W130	Same		1
All	All		27416-0W050	Same	Cap, Alternator Pulley	1

Production Change Information

This bulletin applies to vehicles produced **BEFORE** the Production Change Effective VINs shown below.

MODEL	ENGINE	DRIVETRAIN	PRODUCTION CHANGE EFFECTIVE VIN
Avalon	2GR	2WD	4T1BK3DB#BU428842
Camry	2AR		4T1BF3EK#BU773979
	2GR		4T1BK3EK#BU632735
Camry (SIA)	2AR		4T4BF1FK#CR157292
Highlander	2GR	2WD	5TD#K3EH#CS053568
		AWD	5TD#K3EH#CS100588

Charging System Inoperative

Production Change Information (Continued)

MODEL	ENGINE	DRIVETRAIN	PRODUCTION CHANGE EFFECTIVE VIN
RAV4	2AR	2WD	2T3BF4DV#BW150222
		AWD	2T3YF4DV#BW089082
	2GR	2WD	2T3DK4DV#BW057602
		AWD	2T3YK4DV#BW012939
Sienna	2GR	2WD	5TD#K3DC#CS178536
		AWD	5TD#K3DC#CS030570
Venza	2GR	2WD	4T32K3BB#BU043185
		AWD	4T3BK3BB#BU059392

Warranty Information

OPCODE	DESCRIPTION	MODEL	MODEL YEAR	ENGINE	TIME	OFF	T1	T2
EL1106	R & R Pulley w/Clutch	Avalon	2011	2GR	0.8	27415-0W130	72	50
		Camry	2011	2AR	0.9	27415-0W120		
			2012			27415-0W020		
			2011-2012	2GR	2.4	27415-0W130		
		Highlander	2011-2012	2GR	2.9	27415-0W130		
		RAV4	2011	2AR	0.8	27415-0W020		
				2GR		27415-0W130		
		Sienna	2011-2012	2GR	2.4	27415-0W130		
Venza	2011	2GR	2.8	27415-0W130				

APPLICABLE WARRANTY

- This repair is covered under the Toyota Comprehensive Warranty. This warranty is in effect for 36 months or 36,000 miles, whichever occurs first, from the vehicle's in-service date.
- Warranty application is limited to occurrence of the specified condition described in this bulletin.

Charging System Inoperative

Required Tools & Equipment

SPECIAL SERVICE TOOLS (SST)	PART NUMBER	QTY
GR8 Battery Diagnostic Station*	00002-MCGR8	1
OR		
Digital Battery System Analyzer (NVS-8150)*	00002-V8150-KIT	1
Alternator Clutch Holding Tool Set	09820-63021	1

NOTE

Additional SSTs may be ordered by calling 1-800-933-8335.

* Essential SST.

TSB Overview

Before replacing the pulley, this TSB will lead you through standard charging system diagnostic steps to ensure that the low charge condition is not caused by some other component.

1. Check battery condition.
2. Check fuses, belts, and alternator wiring.
3. Check alternator, warning light, and charging circuit under load.
4. Check alternator clutch pulley function and replace if needed.

Repair Procedure

1. Check the battery condition.
 - A. Check the battery for damage and deformation. If severe damage, deformation, or leakage is found, replace the battery.
 - B. Check the battery using the GR8 Battery Diagnostic Station or the Digital Battery System Analyzer (NVS-8150). If the battery diagnostics fail, replace the battery and continue with the next step.

NOTE

For details on how to use the GR8 Battery Diagnostic Station or the Digital Battery System Analyzer, refer to the instruction manual on the Technical Information System (TIS), *Diagnostics – Tools & Equipment – Battery Diagnostics –*

- [GR8 Instruction Manual](#)
- [NVS-8150 Instruction Manual](#)

Charging System Inoperative

Repair Procedure (Continued)

- C. Inspect the battery terminal and check that the battery terminals are not loose or corroded.
- 2. Check fuses.
 - A. Measure the resistance of each fuse for the charging system.

HINT

The fuses shown in the Charging System Diagram are related to the charging system.

Standard Resistance: Below 1 Ω

If any of the results are not as specified, replace the fuse(s) as necessary.

- 3. Check the V-ribbed belt.
 - A. Check the belt for wear, cracks, or other signs of damage. If any of the following conditions are found, replace the V-ribbed belt.
 - The belt is cracked.
 - The belt is worn out to the extent that the cords are exposed.
 - The belt has chunks missing from the ribs.

Figure 1.

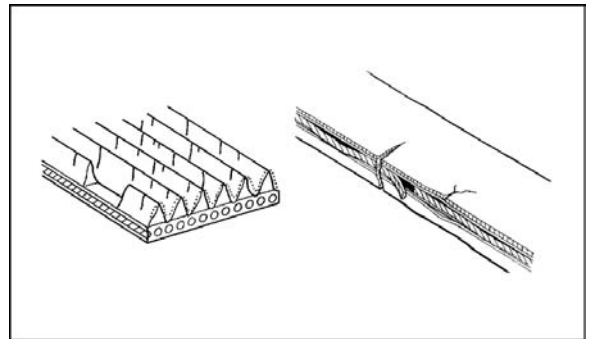

- B. Check that the belt fits properly in the ribbed grooves.

Figure 2.

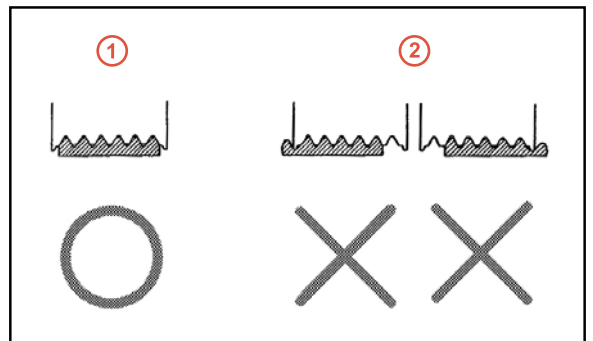

HINT

- Check with your hand to confirm that the belt has NOT slipped out of the groove on the bottom of the pulley.
- If it has slipped out, replace the V-ribbed belt. Install a new V-ribbed belt correctly.

1	Correct
2	Incorrect

Charging System Inoperative

Repair Procedure (Continued)

4. Inspect the alternator wiring.
 - A. Visually check that the alternator wiring is in good condition.
 - B. Check voltage at IG and at IG and S/RLO* terminals.

* RLO = RAV4, S = All Except RAV4

- (1) Disconnect the appropriate connector at the alternator:

Figure 3. Avalon: B6

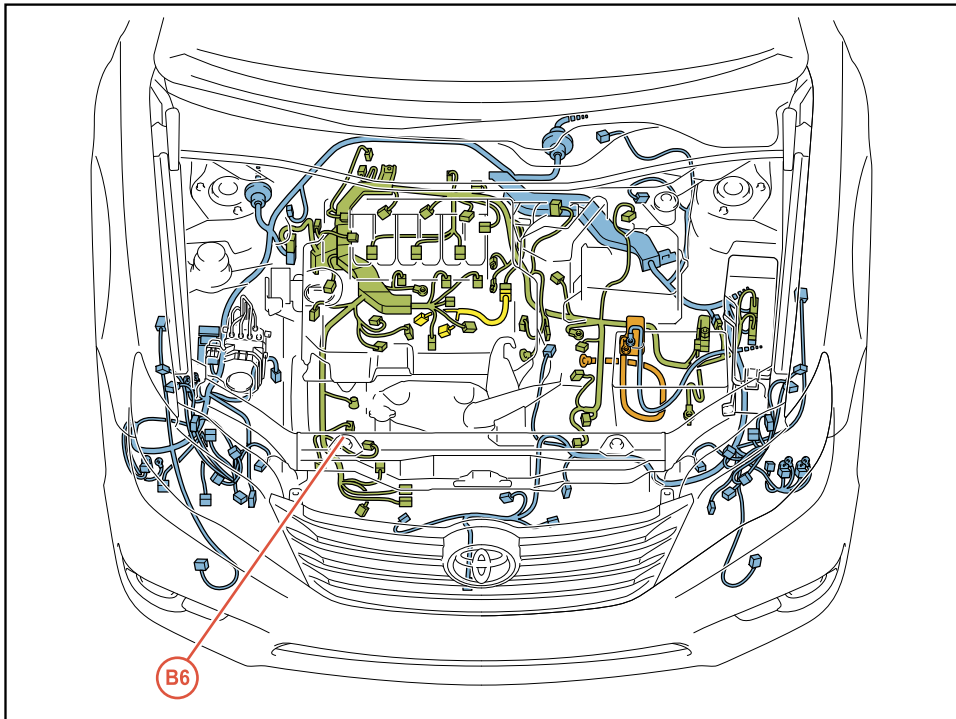

Charging System Inoperative

Repair Procedure (Continued)

Figure 4. Camry: C18

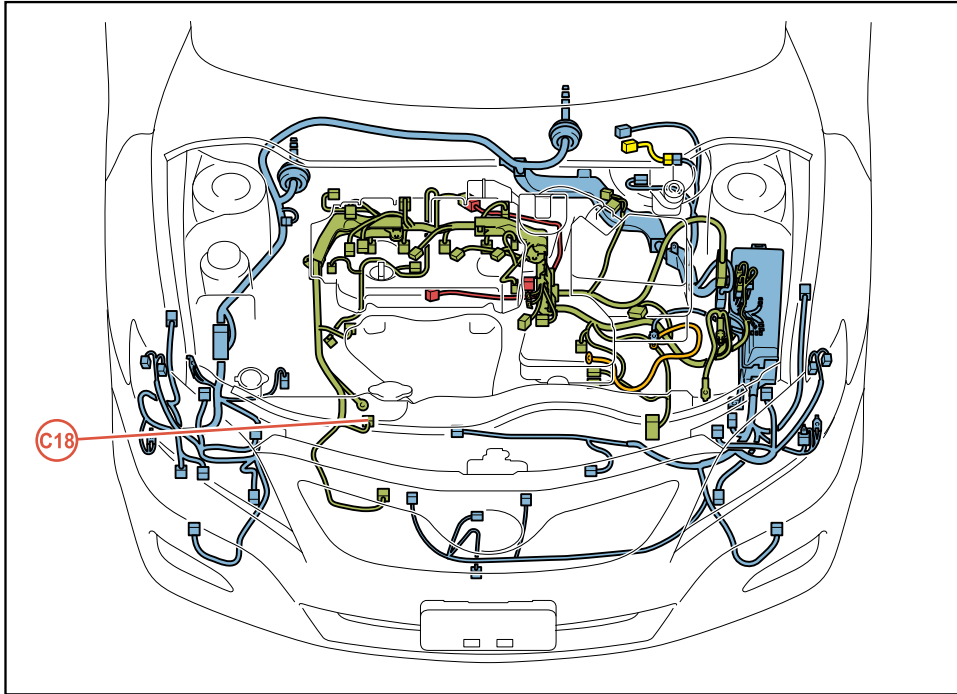
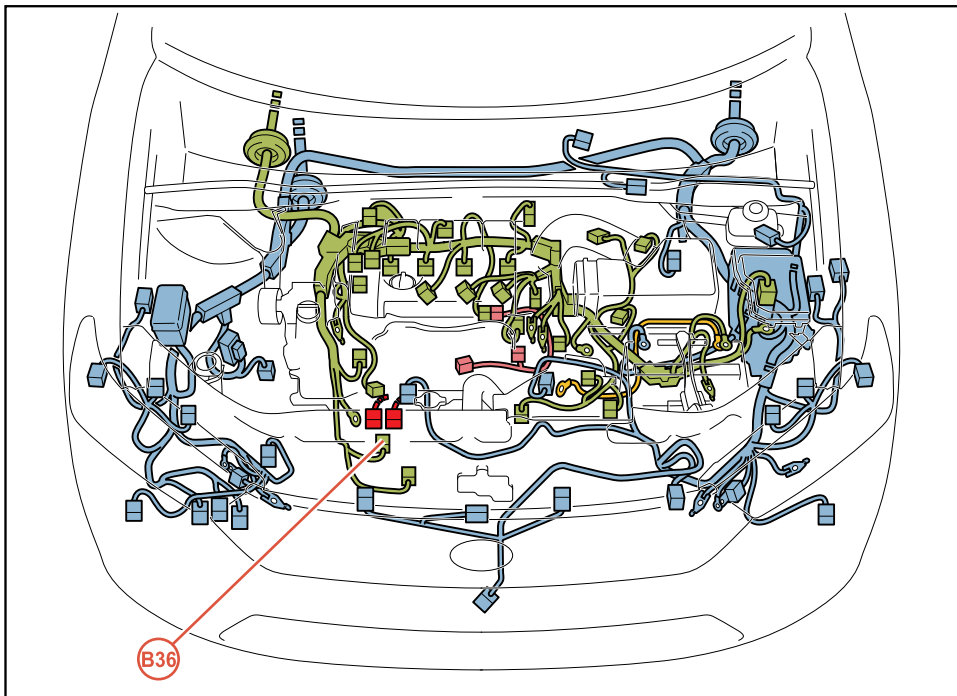

Figure 5. Highlander: B36



Charging System Inoperative

Repair Procedure (Continued)

Figure 6. RAV4: B21

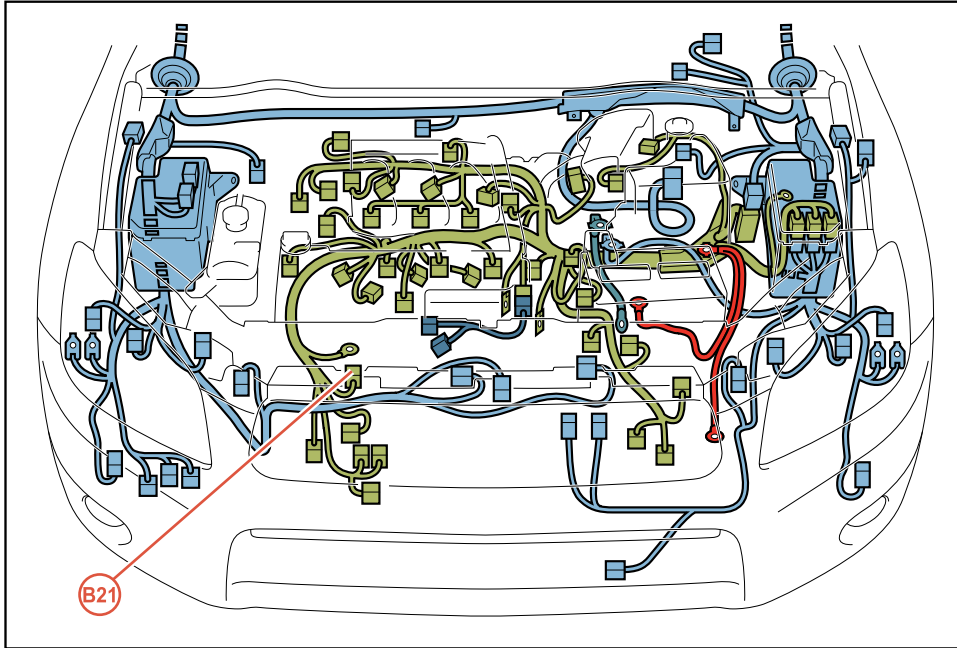
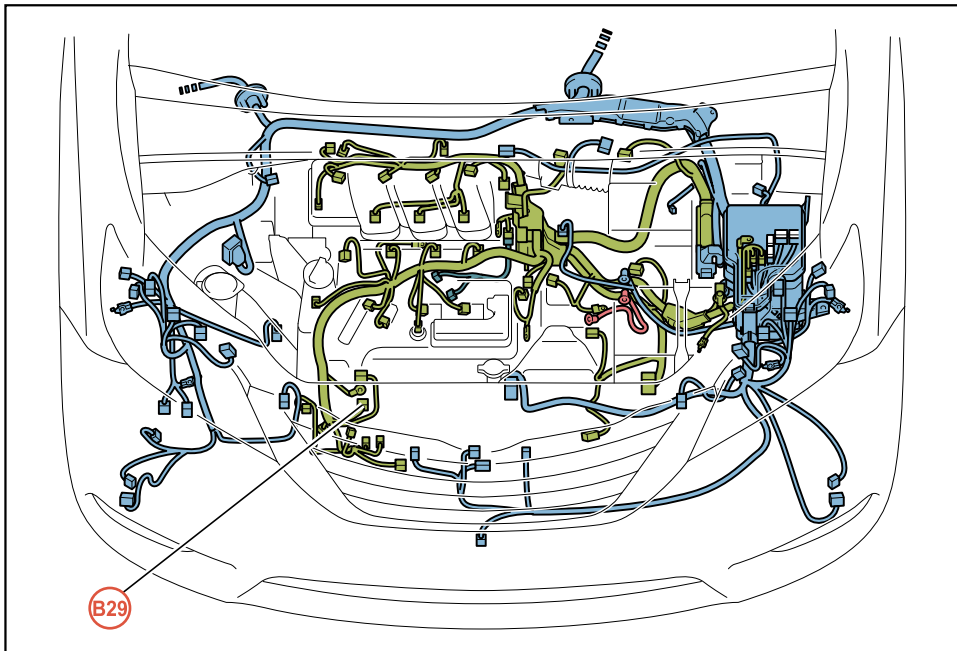

Figure 7. Sienna: B29



Charging System Inoperative

Repair Procedure (Continued)

Figure 8. Venza: B10

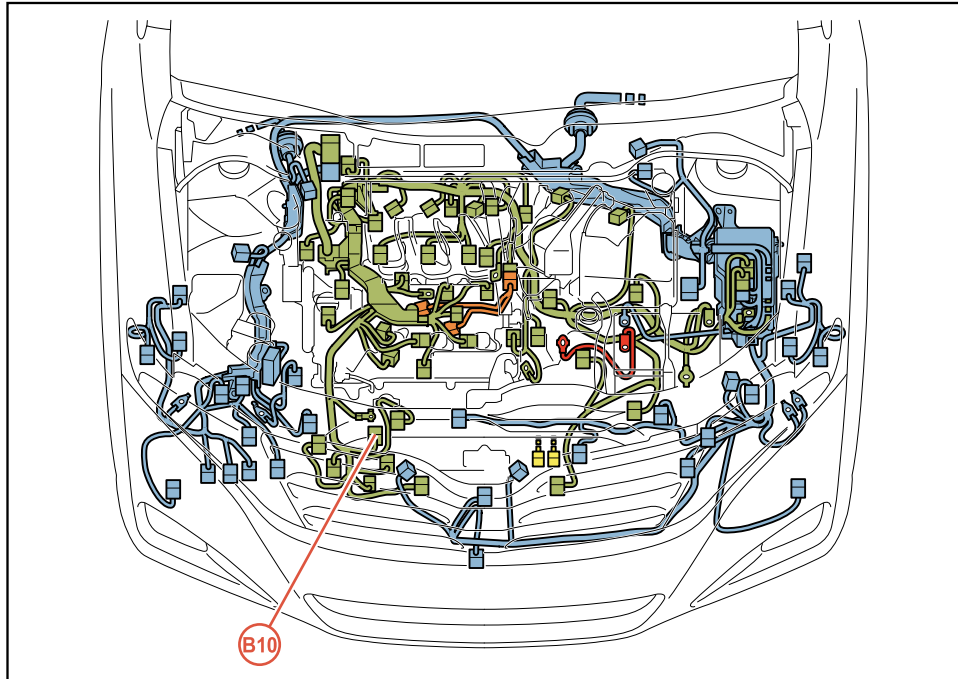

- (2) Turn ignition (IG) to the ON position.
- (3) Measure the voltage according to the value(s) in the table below.

TESTER CONNECTION	SPECIFIED CONDITION
Positive (+) Lead Pin 2 (IG) Negative (-) Lead Negative Battery Terminal	10 – 14 V
Positive (+) Lead Pin 1 (S/RLO) Negative (-) Lead Negative Battery Terminal	

If voltage is not as specified, refer to TIS to diagnose the circuit:

- *Reference Information – Technician Group – [Quick Reference: Body Electrical Diagnosis](#)*

5. Check for noises from the alternator.

Listen and check that NO abnormal noises are heard from the alternator while the engine is running.

Charging System Inoperative

Repair Procedure (Continued)

6. Inspect the charge warning light circuit.

A. Turn the engine switch (IG) ON. Check that the charge warning light comes on.

B. Start the engine and check that the light goes OFF.

If the light does NOT operate as specified, troubleshoot the charge warning light circuit.

7. Inspect the charging circuit without load.

A. Connect a voltmeter and an ammeter to the charging circuit as follows.

- (1) Disconnect the wire from terminal B of the alternator and connect it to the negative (-) lead of the ammeter.
- (2) Connect the ammeter positive (+) lead to terminal B of the alternator.
- (3) Connect the voltmeter positive (+) lead to the positive (+) terminal of the battery.
- (4) Ground the voltmeter negative (-) lead.

Figure 9.

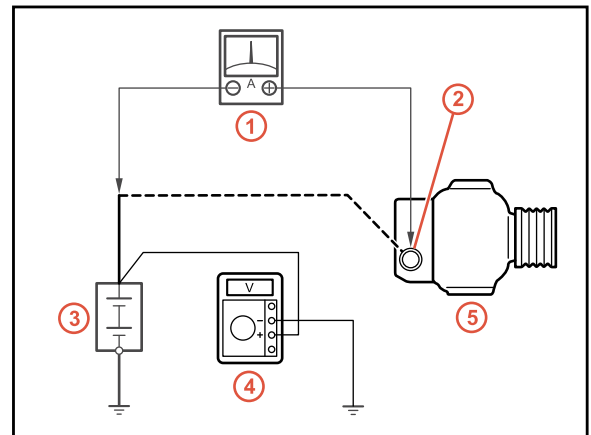

1	Ammeter
2	Terminal B
3	Battery
4	Voltmeter
5	Alternator

Charging System Inoperative

Repair Procedure (Continued)

B. Check the charging circuit.

Keep the engine speed at 2000 rpm and check the reading on the ammeter and voltmeter.

Standard Current: 10 A or less

Standard Voltage: 13.2 to 14.8 V

- If the result is NOT as specified, go to step 9.
- If the results are as specified, go to step 8.

HINT

If the battery is not fully charged, the ammeter reading will sometimes be more than the standard current.

8. Inspect charging circuit with load.

A. With the engine running at 2000 rpm, turn the high beam headlights on and turn the heater blower switch to the "HI" position.

B. Check the reading on the ammeter.

Standard Current: 30A or more

- If the ammeter reading is less than the standard current, go to step 9.
- If the current is 30A or more, **STOP** — This TSB does NOT apply, the charging system is operating normally.

HINT

If the battery is fully charged, the indication will sometimes be less than the standard current. If this is the case, add more electrical load (operate the wipers, rear window defogger, etc.) and check the reading on the ammeter again.

9. Check lock function of alternator clutch pulley.

A. Check the lock function with the pulley installed in the vehicle. Visually check that the rotor in the alternator operates with the engine running.

- If the pulley does NOT operate with the engine running, go to step 10.
- If the pulley operates with the engine running, go to step B (remove alternator).

B. Remove the alternator.

Refer to TIS, applicable model and model year Repair Manual:

- 2011 Avalon:
Power Source/Network – Battery/Charging – “2GR-FE Charging: Generator: Removal (to 12/2010) / (from 12/2010)”

Charging System Inoperative

Repair Procedure (Continued)

- 2011 Camry:
Power Source/Network – Battery/Charging – [“2AR-FE / 2GR-FE Charging: Generator: Removal”](#)
 - 2012 Camry:
Power Source/Network – Battery/Charging – [“2AR-FE / 2GR-FE Battery/Charging: Generator: Removal”](#)
 - [2011 / 2012](#) Highlander:
Power Source/Network – Battery/Charging – [“2GR-FE Charging: Generator: Removal”](#)
 - 2011 RAV4:
Power Source/Network – Battery/Charging – [“2AR-FE / 2GR-FE Charging: Generator: Removal”](#)
 - [2011 / 2012](#) Sienna:
Power Source/Network – Battery/Charging – [“2GR-FE Battery/Charging: Generator: Removal”](#)
 - 2011 Venza:
Power Source/Network – Battery/Charging – [“2GR-FE Battery/Charging: Generator: Removal”](#)
- C. Check the lock function with the pulley removed from the vehicle.
- (1) Remove the alternator pulley cap.

Using a screwdriver, puncture the center of the alternator pulley cap and pry it off.

NOTE

Do NOT reuse the alternator pulley cap.

Charging System Inoperative

Repair Procedure (Continued)

- (2) Hold the alternator rotor using the SST, and turn the clutch pulley clockwise to check that the outer ring locks.

SST: 09820-63021

- **OK:** The outer ring locks.
If OK, **STOP** — This TSB does NOT apply, replace the alternator.
- **NG:** The outer ring does NOT lock, replace the alternator clutch pulley.

Figure 10.

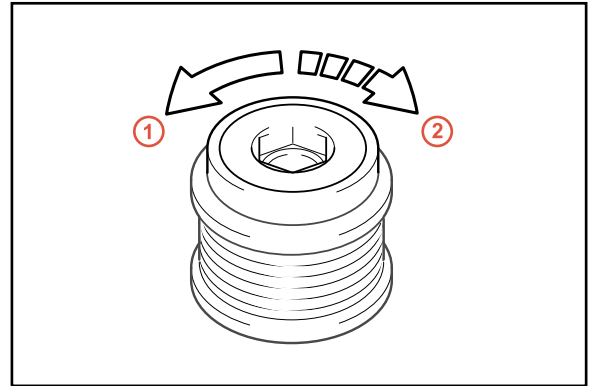

1	Free
2	Lock

10. Remove the alternator clutch pulley.

- A. Mount the alternator drive end frame in a vise tightly.

SST: 09820-63021

Figure 11.

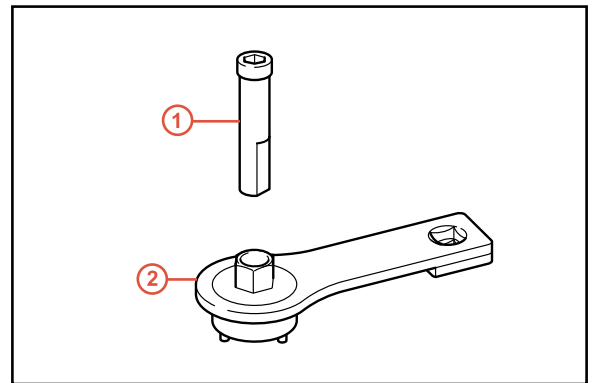

1	SST (A)
2	SST (B)

Charging System Inoperative

Repair Procedure (Continued)

B. Place the rotor shaft end into SST (A).

Figure 12.

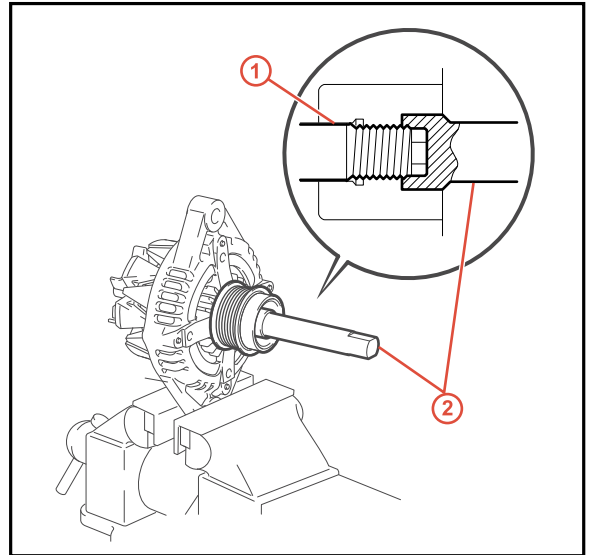

1	Rotor Shaft
2	SST (A)

Charging System Inoperative

Repair Procedure (Continued)

C. Attach SST (B) to the clutch pulley.

Figure 13.

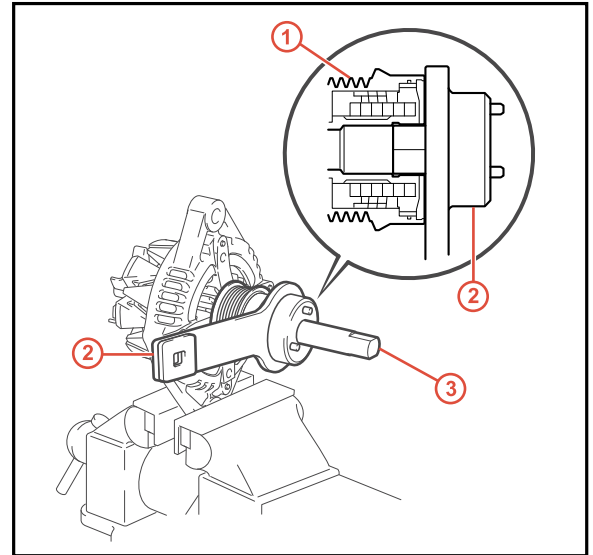

1	Clutch Pulley
2	SST (B)
3	SST (A)

D. Loosen the pulley by turning SST (B) in the direction shown in the illustration.

Figure 14.

NOTICE

- Check that the drive end frame is secured in the vise tightly.
- Hold SST (A) tightly during the operation.

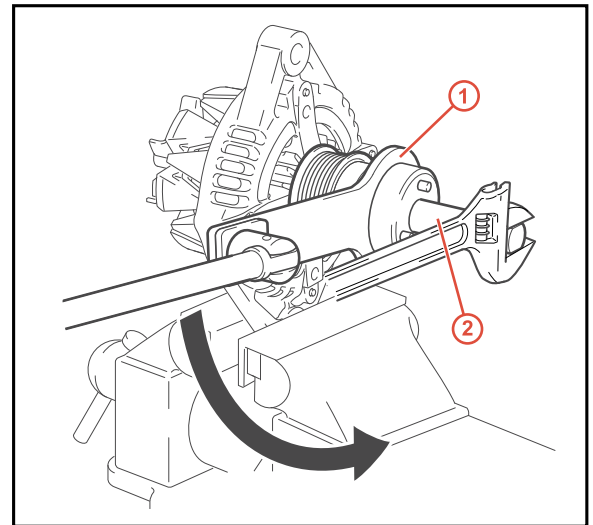

1	SST (B)
2	SST (A)

Charging System Inoperative

Repair Procedure (Continued)

- E. Remove the SST from the alternator assembly.
 - F. Remove the clutch pulley from the rotor shaft.
11. Install the alternator clutch pulley.
- A. Temporarily install the clutch pulley onto the rotor shaft.
 - B. Place the rotor shaft end into SST (A).

SST: 09820-63021

Figure 15.

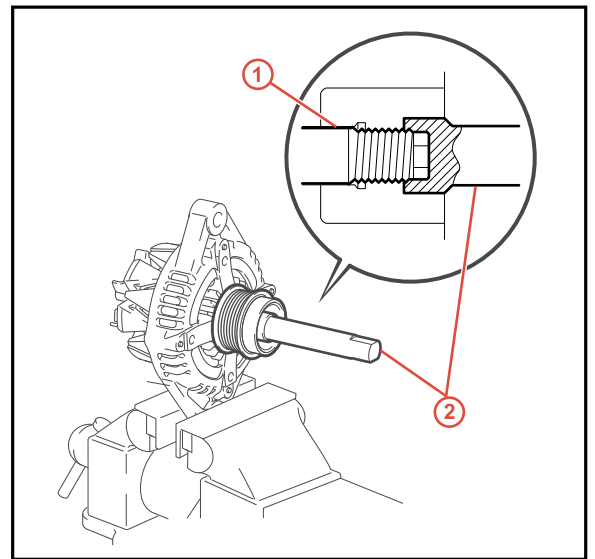

1	Rotor Shaft
2	SST (A)

Charging System Inoperative

Repair Procedure (Continued)

C. Attach SST (B) to the clutch pulley.

Figure 16.

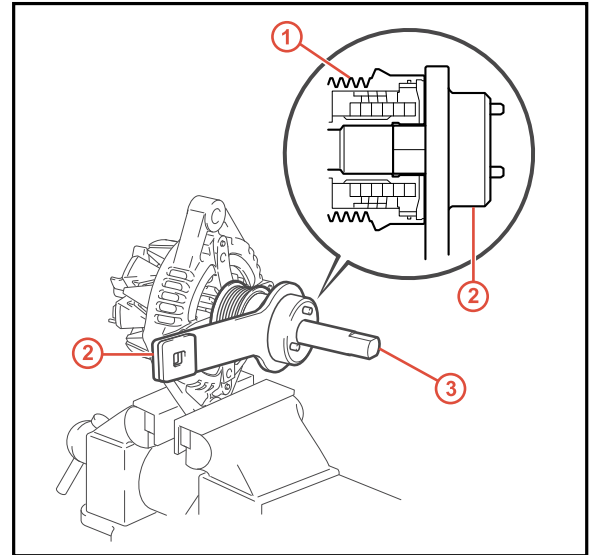

1	Clutch Pulley
2	SST (B)
3	SST (A)

D. Tighten the pulley by turning SST (B) in the direction shown in the illustration.

Torque: 64 N*m (653 kgf*cm, 47 ft*lbf)

Figure 17.

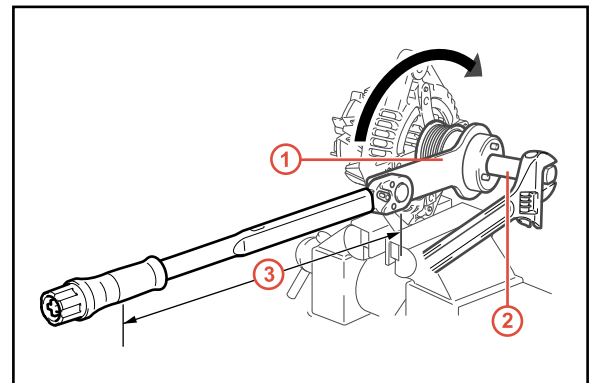

1	SST (B)
2	SST (A)
3	Fulcrum Length: 400 mm

NOTE

- The torque value is effective when using a torque wrench with a fulcrum length of 400 mm (1.312 ft.).
- This torque value is effective when SST is parallel to the torque wrench.

NOTICE

- Check that the drive end frame is secured in the vise tightly.
- Hold SST (A) tightly during the operation.

Charging System Inoperative

Repair Procedure (Continued)

- E. Remove the SST from the alternator assembly.
- F. Check that the clutch pulley rotates smoothly.
- G. Install a new alternator pulley cap to the clutch pulley.

12. Install the alternator.

Refer to TIS, applicable model and model year Repair Manual:

- 2011 Avalon:
Power Source/Network – Battery/Charging – “2GR-FE Charging: Generator: Installation (to 12/2010) / (from 12/2010)”
- 2011 Camry:
Power Source/Network – Battery/Charging – “[2AR-FE](#) / [2GR-FE](#) Charging: Generator: Installation”
- 2012 Camry:
Power Source/Network – Battery/Charging – “[2AR-FE](#) / [2GR-FE](#) Battery/Charging: Generator: Installation”
- [2011](#) / [2012](#) Highlander:
Power Source/Network – Battery/Charging – “2GR-FE Charging: Generator: Installation”
- 2011 RAV4:
Power Source/Network – Battery/Charging – “[2AR-FE](#) / [2GR-FE](#) Charging: Generator: Installation”
- [2011](#) / [2012](#) Sienna:
Power Source/Network – Battery/Charging – “2GR-FE Battery/Charging: Generator: Installation”
- 2011 Venza:
Power Source/Network – Battery/Charging – “[2GR-FE](#) Battery/Charging: Generator: Installation”

13. Confirm the charge indicator lamp is NOT illuminated and the charging system is operating properly as described in steps 7 and 8.

14. Re-initialize affected electrical systems.

Refer to TIS, applicable model and model year Repair Manual:

- [2011](#) Avalon:
General – Introduction – “Introduction: Repair Instruction: Initialization”
- 2011 Camry:
Re-initialization not necessary.

Charging System Inoperative

Repair Procedure (Continued)

- [2012](#) Camry:
General – Introduction – “Introduction: Repair Instruction: Initialization”
- [2011](#) / [2012](#) Highlander:
General – Introduction – “Introduction: Repair Instruction: Initialization”
- 2011 RAV4:
Re-initialization not necessary.
- [2011](#) / [2012](#) Sienna:
General – Introduction – “Introduction: Repair Instruction: Initialization”
- [2011](#) Venza:
General – Introduction – “Introduction: Repair Instruction: Initialization”